

E-Flo[®] 4-Ball Piston Pumps

311594Z
EN

**Durable, energy efficient piston pumps for high volume paint circulation applications.
For professional use only.**



Important Safety Instructions

Read all warnings and instructions in this manual.
Save these instructions.

See page 3 for model information, including maximum working pressure. See page 5 for approvals.

E-Flo 4000 Pump Shown

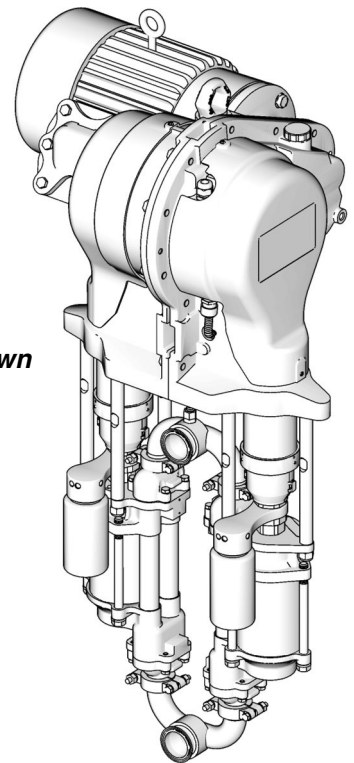

ti8317c

Contents

Related Manuals	2
Models	3
E-Flo 4-Ball Piston Pumps	3
Maximum Working Pressure and Pump Operational Limits	3
Approvals	5
Warnings	6
Pressure Relief Procedure	9
Flushing	9
Troubleshooting	10
Electrical Diagrams	12
Repair	15
Fluid Section	15
Disassembly	15
Reassembly	17
Slider Cylinder Rebuild Kit 15H874	18
Slider Cylinder Collector Kit 247341	19
Electrical Section	20
Pressure Transducer Kit 15H876	20
Pressure Sensor Calibration Information (non-ACS systems)	22

Pressure Transducer Calibration Procedure (non-ACS systems)	22
TDC Sensor Kit 15H877	23
Position Sensor	24
Drive Section	26
Slider Bearing Kit 15H882	26
Drive Linkage Rebuild Kit 15H873	28
Crank Arm Kit 15H883	29
Motor/Gear Reducer	30
Motor Removal	30
Motor/Coupler is Difficult to Remove	31
Motor Installation	33
Gear Reducer Seal Kit 15H871	34
Gear Reducer Replacement Kit	36
Parts	42
Drive Section	42
Fluid Section	43
Common Parts	44
Model-Specific Parts	46
Gear Reducer	49
Technical Data	50
Graco Standard Warranty	52
Graco Information	52

Related Manuals

Manual	Description
311592	E-Flo Installation Manual
311593	E-Flo Operation Manual
311595	Pneumatic Back Pressure Regulator
311596	Variable Frequency Drive Instructions
311603	Sensor Circuit Option
3A0539	4-Ball Lowers

Models

E-Flo 4-Ball Piston Pumps

Check your pump's identification plate (ID) for the 6-digit part number of your pump. Use the following matrix to define the construction of your pump, based on the six digits. For example, Pump Part No. **E P 2 1 6 0** represents electric power (**E**), pump (**P**), 230/460V motor (**2**), sensor circuit installed (**1**), 2000 cc MaxLife lower (**6**), and no stand installed (**0**). To order replacement parts, see **Parts**, beginning on page 42.

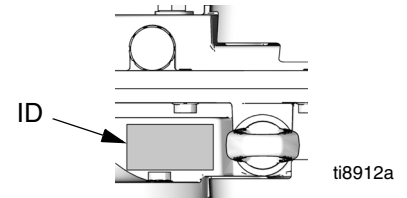

E	P	2		1		6		0	
First Digit	Second Digit	Third Digit		Fourth Digit		Fifth Digit		Sixth Digit	
Power Source	Equipment Style	Motor		Sensor Circuit		Lower Size		Stand Option	
E (electric)	P (pump)	0	No motor	0	No circuit installed	1	1000 cc Chrome	0	No stand installed
		1	230/400V, 5HP, ATEX	1	Circuit installed	2	1500 cc Chrome	1	Stand installed
		2	230/460V, 5HP, UL/CSA			3	2000 cc Chrome		
		3	230/400V, 3HP, ATEX			4	1000 cc MaxLife®		
		4	230/460V, 3HP, UL/CSA			5	1500 cc MaxLife		
						6	2000 cc MaxLife		
						7	750 cc Chrome		
						8	750 cc MaxLife		

Maximum Working Pressure and Pump Operational Limits

E-Flo 1500: 425 psi (2.93 MPa, 29.3 bar) Maximum Working Pressure

E-Flo 2000: 460 psi (3.22 MPa, 32.2 bar) Maximum Working Pressure







E-Flo 3000: 330 psi (2.31 MPa, 23.1 bar) Maximum Working Pressure

E-Flo 4000: 250 psi (1.75 MPa, 17.5 bar) Maximum Working Pressure

See **Technical Data**, page 50, for pressure and flow limits.

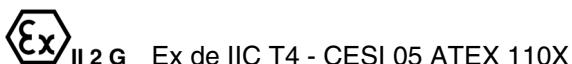

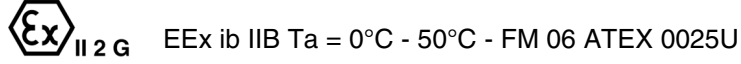
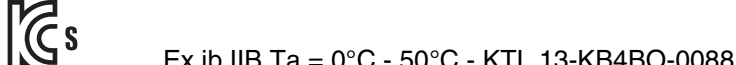

Approvals







The E-Flo Pump meets requirements of the following approval agencies.
 Refer to the individual components for other specific hazardous location listings.

Component	Part No.	Approvals
Mechanical Pump		 
Motor	ATEX EP1XXX EP3XXX	 
	UL/CSA EP2XXX EP4XXX	 Class I, Group D, Class II, Group F and G, Division 1, T3B Hazardous Locations 
IS Sensor Circuit	EPX1XX	   



Warnings

The following warnings are for the setup, use, grounding, maintenance, and repair of this equipment. The exclamation point symbol alerts you to a general warning and the hazard symbols refer to procedure-specific risks. When these symbols appear in the body of this manual, refer back to these Warnings. Product-specific hazard symbols and warnings not covered in this section may appear throughout the body of this manual where applicable.

 WARNING	
 	<p>FIRE AND EXPLOSION HAZARD</p> <p>Flammable fumes, such as solvent and paint fumes, in work area can ignite or explode. To help prevent fire and explosion:</p> <ul style="list-style-type: none"> • Use equipment only in well ventilated area. • Eliminate all ignition sources; such as pilot lights, cigarettes, portable electric lamps, and plastic drop cloths (potential static arc). • Keep work area free of debris, including solvent, rags and gasoline. • Do not plug or unplug power cords, or turn power or light switches on or off when flammable fumes are present. • Ground all equipment in the work area. See Grounding instructions. • Use only grounded hoses. • Hold gun firmly to side of grounded pail when triggering into pail. • If there is static sparking or you feel a shock, stop operation immediately. Do not use equipment until you identify and correct the problem. • Keep a working fire extinguisher in the work area. <p>Static charge may build up on plastic parts during cleaning and could discharge and ignite flammable vapors. To help prevent fire and explosion:</p> <ul style="list-style-type: none"> • Clean plastic parts only in a well ventilated area. • Do not clean with a dry cloth. • Do not operate electrostatic guns in equipment work area. •
	<p>EQUIPMENT MISUSE HAZARD</p> <p>Misuse can cause death or serious injury.</p> <ul style="list-style-type: none"> • Do not operate the unit when fatigued or under the influence of drugs or alcohol. • Do not exceed the maximum working pressure or temperature rating of the lowest rated system component. See Technical Data in all equipment manuals. • Use fluids and solvents that are compatible with equipment wetted parts. See Technical Data in all equipment manuals. Read fluid and solvent manufacturer's warnings. For complete information about your material, request MSDS forms from distributor or retailer. • Check equipment daily. Repair or replace worn or damaged parts immediately with genuine manufacturer's replacement parts only. • Do not alter or modify equipment. • Use equipment only for its intended purpose. Call your distributor for information. • Route hoses and cables away from traffic areas, sharp edges, moving parts, and hot surfaces. • Do not kink or over bend hoses or use hoses to pull equipment. • Keep children and animals away from work area. • Comply with all applicable safety regulations.

 WARNING	
	<p>ELECTRIC SHOCK HAZARD</p> <p>Improper grounding, setup, or usage of the system can cause electric shock.</p> <ul style="list-style-type: none"> • Turn off and disconnect power at main switch before disconnecting any cables and before servicing equipment. • Connect only to grounded power source. • All electrical wiring must be done by a qualified electrician and comply with all local codes and regulations.
	<p>PRESSURIZED EQUIPMENT HAZARD</p> <p>Fluid from the gun/dispense valve, leaks, or ruptured components can splash in the eyes or on skin and cause serious injury.</p> <ul style="list-style-type: none"> • Follow Pressure Relief Procedure in this manual, when you stop spraying and before cleaning, checking, or servicing equipment. • Tighten all fluid connections before operating the equipment. • Check hoses, tubes, and couplings daily. Replace worn or damaged parts immediately.
	<p>MOVING PARTS HAZARD</p> <p>Moving parts can pinch or amputate fingers and other body parts.</p> <ul style="list-style-type: none"> • Keep clear of moving parts. • Do not operate equipment with protective guards or covers removed. • Pressurized equipment can start without warning. Before checking, moving, or servicing equipment, follow the Pressure Relief Procedure in this manual. Disconnect power or air supply.
	<p>TOXIC FLUID OR FUMES HAZARD</p> <p>Toxic fluids or fumes can cause serious injury or death if splashed in the eyes or on skin, inhaled, or swallowed.</p> <ul style="list-style-type: none"> • Read MSDS's to know the specific hazards of the fluids you are using. • Store hazardous fluid in approved containers, and dispose of it according to applicable guidelines. • Always wear impervious gloves when spraying or cleaning equipment.
	<p>PERSONAL PROTECTIVE EQUIPMENT</p> <p>You must wear appropriate protective equipment when operating, servicing, or when in the operating area of the equipment to help protect you from serious injury, including eye injury, inhalation of toxic fumes, burns, and hearing loss. This equipment includes but is not limited to:</p> <ul style="list-style-type: none"> • Protective eyewear • Clothing and respirator as recommended by the fluid and solvent manufacturer • Gloves • Hearing protection
	<p>BURN HAZARD</p> <p>Equipment surfaces and fluid that's heated can become very hot during operation. To avoid severe burns, do not touch hot fluid or equipment. Wait until equipment/fluid has cooled completely.</p>

Pressure Relief Procedure

						
System pressure can cause the pump to cycle unexpectedly, which could result in serious injury from splashing or moving parts.						

1. Set START/STOP switch (ST) to STOP.
2. Push in SECURE DISABLE (SD) switch.
3. Open the back pressure regulator and all fluid drain valves in the system, having a waste container ready to catch drainage. Leave open until you are ready to pressurize system again.
4. Check that pressure gauges on fluid supply and return lines read zero. If gauges do not read zero, determine cause and carefully relieve pressure by VERY SLOWLY loosening a fitting. Clear obstruction before pressurizing system again.

Flushing

						
---	--	--	--	--	--	--

- Flush before changing colors, before storing, and before repairing equipment.
 - Flush at the lowest pressure possible. Check connectors for leaks and tighten as necessary.
 - Flush with a fluid that is compatible with the fluid being dispensed and the equipment wetted parts.
1. Follow **Pressure Relief Procedure**, page 9.
 2. Supply the appropriate flushing material to the system.
 3. Set pump to lowest possible fluid pressure, and start the pump.
 4. Flush long enough to thoroughly clean the system.
 5. Follow **Pressure Relief Procedure**, page 9.

Troubleshooting

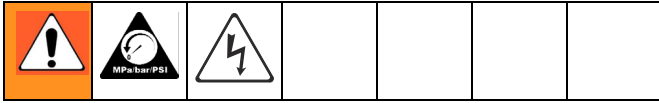

1. Relieve the pressure.
2. Check all possible problems and solutions before disassembling pump.

PROBLEM	CAUSE	SOLUTION
Pump does not operate.	Insufficient power supply.	Verify that power supply meets requirements. See Technical Data , page 50.
	No flow rate input to VFD.	Select speed/flow setting.
	START/STOP switch set to STOP.	Set START/STOP switch to START.
	SECURE DISABLE switch not activated.	Pull out to activate.
	Outlet valve not open.	Open valve.
	Damaged electric motor.	Repair, page 20.
	Damaged gear reducer.	Disconnect pumps and operate. If speed is consistent, gear reducer is good. If speed is erratic, gear reducer is bad.
	Fluid dried on piston rod.	Disassemble and clean lower. See lower manual. In future, stop lower at bottom of stroke.
	Throat packing nut is too tight.	Loosen packing nut and retighten.
Pressure too low.	3-phase wiring to motor is not correct.	Inspect and confirm wiring continuity.
	Incorrect transducer calibration.	Check calibration. Replace transducer if necessary.
	Lowers need repair.	Check and repair. See lower manual.
	Restricted pump fluid inlet.	Clear.
Pump output low on both strokes.	Air in the fluid.	Check fluid level. Check inlet fittings for leaks.
	Insufficient power supply.	Verify that power supply meets requirements. See Technical Data , page 50.
	Exhausted fluid supply.	Refill and reprime pump.
	Held open or worn ball check valves.	Check and repair.
Pump output low on only one stroke.	Wrong fluid lowers installed.	Verify size of lowers installed and configured.
	Held open or worn ball check valves.	Check and repair.
	Worn piston packings.	Replace. See lower manual.
Erratic flow or pressure.	Air in the fluid.	Check fluid level. Check inlet fittings for leaks.
	Pump cavitation; suction/supply line leak.	Check and repair.
	Exhausted fluid supply.	Refill and reprime pump.
	Restricted fluid supply to pump.	Ensure all valves are fully open.
	Held open or worn ball check valves.	Check and repair.
	Pump packings are too tight.	Loosen and retighten.
	Worn piston packing.	Replace. See lower manual.
	Motor rotation direction is backwards.	Check direction of rotation.
	3-phase wiring to motor is not correct.	Inspect and confirm wiring continuity.

PROBLEM	CAUSE	SOLUTION
Pump will not prime	Suction line clogged.	Clear. Flush more frequently.
	Held open or worn ball check valves.	Check and repair.
	Lower piston assembled with wrong nut.	Use only the large, round, special nut.
Excessive throat leakage.	Worn piston rod or throat packings.	Replace. See lower manual.
High current trip (t043).	Pressure setting is too high.	Reduce pressure.
	Pump packings are too tight.	Loosen and retighten.
	Gear reducer oil level is low.	Fill to correct oil level.
	Incorrect transducer calibration.	Perform calibration procedure.
	Wrong fluid lowers installed.	Verify size of lowers installed and configured.
High pressure trip (t040).	Downstream restriction is too high.	Open line and remove restriction.
	Circulation valve is closed.	Open back pressure regulator. Check solenoid.
	Clogged fluid filters.	Clean.
	Incorrect transducer calibration.	Perform calibration procedure.
Excessive noise.	Gear reducer oil level is low.	Fill to correct oil level.
	Loose or worn drive linkage.	Inspect; repair or replace.
	Worn motor coupling.	Inspect; repair or replace.
	Worn gear reducer.	Replace.
Pump changes direction or shakes.	One leg of 3-phase is lost.	Inspect and correct wiring connections on VFD, motor, and wiring.

Electrical Diagrams

FIG. 1 shows components which must be installed in a non-hazardous location.

FIG. 2 shows components approved for installation in a hazardous location, and FIG. 3 shows detail views of hazardous location components.

- ① 12 Gauge Alpha Wire P/N V16012/equiv.
- ② 16 Gauge MTW Wire.
- ③ Blue/White 16 Gauge MTW Wire.
- ④ Blue 16 Gauge MTW Wire.

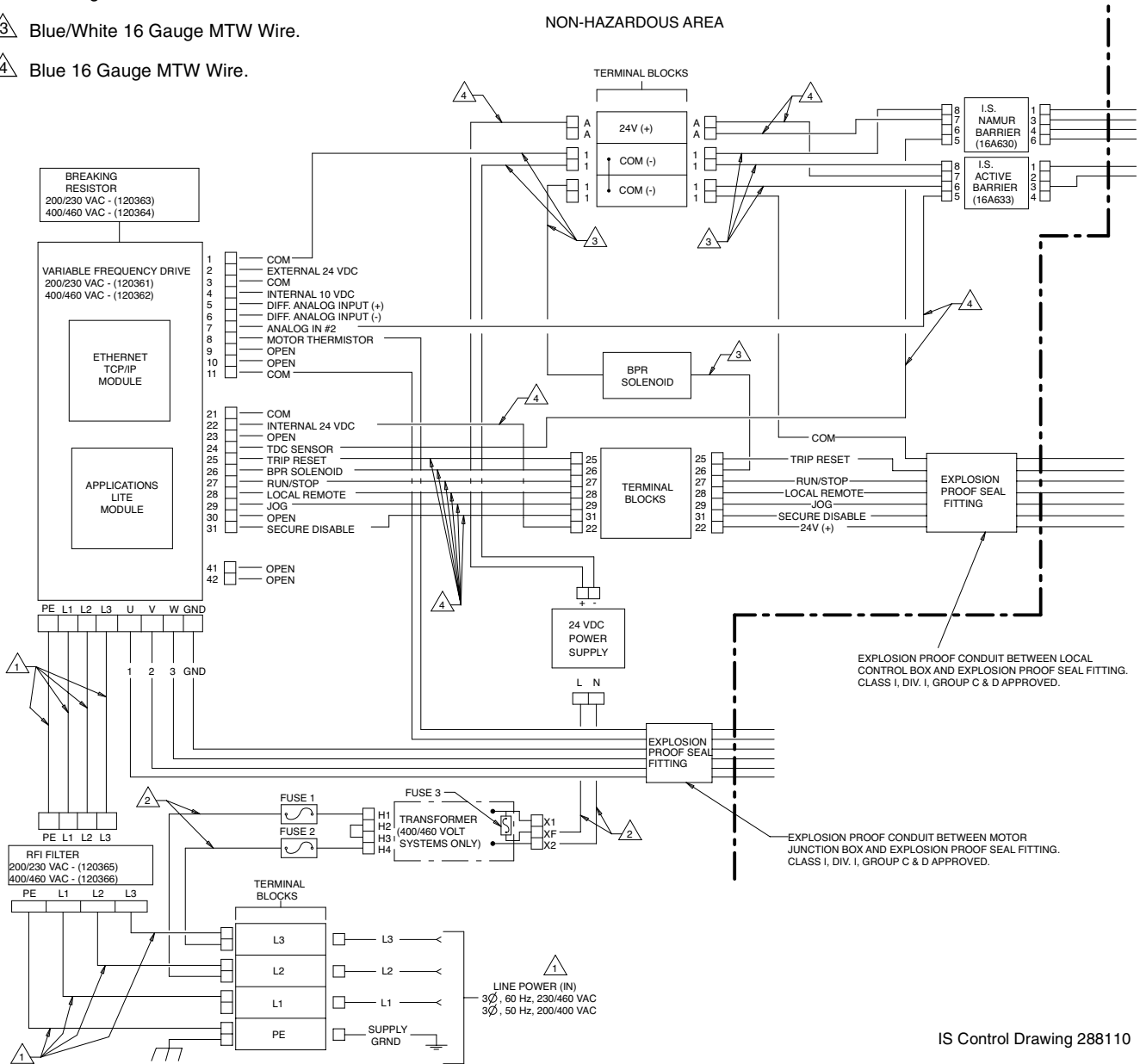

Fig. 1: System Wiring Schematic, Non-Hazardous Location Only

△ Alpha Wire P/N M16107LW/equiv.

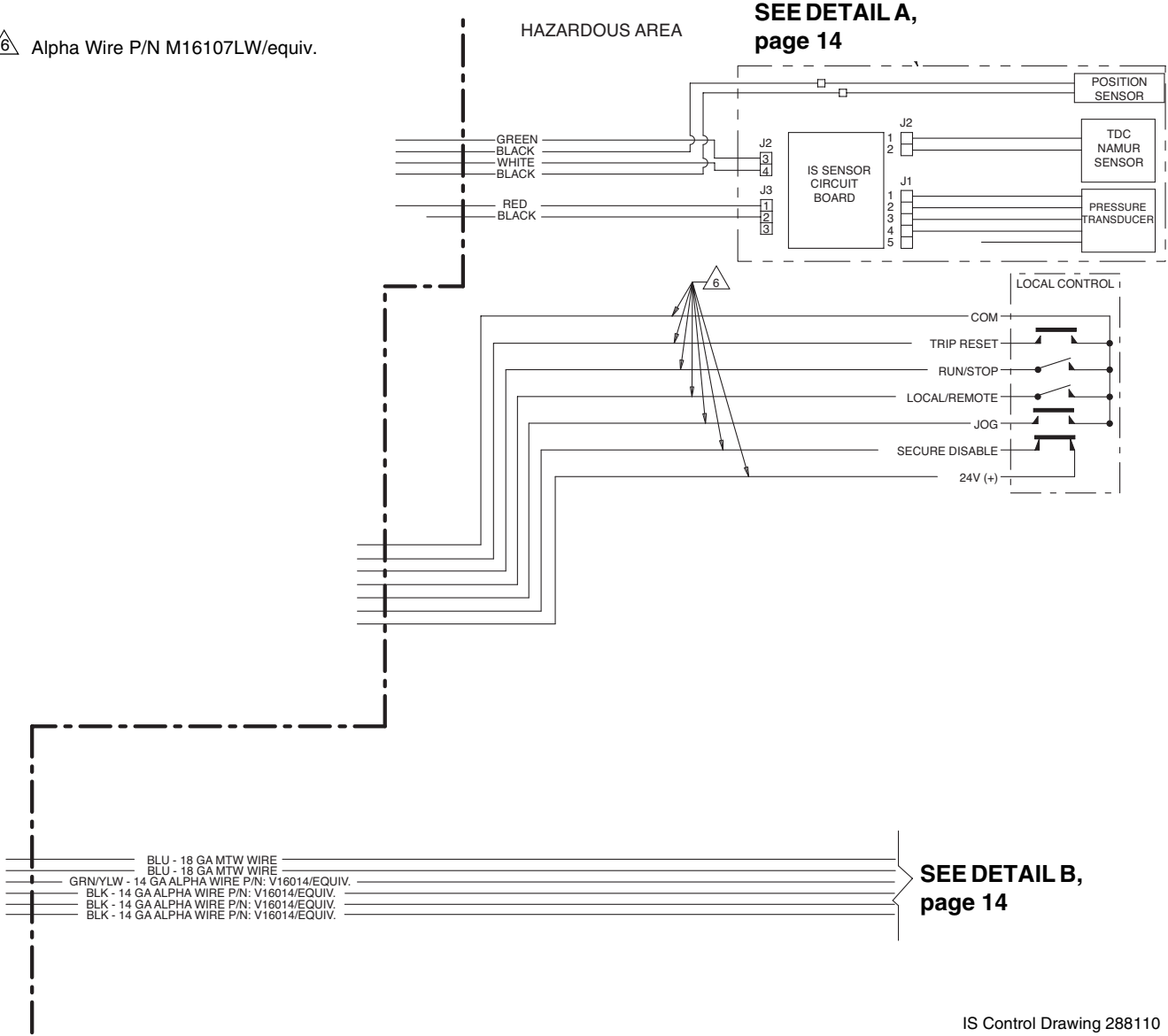
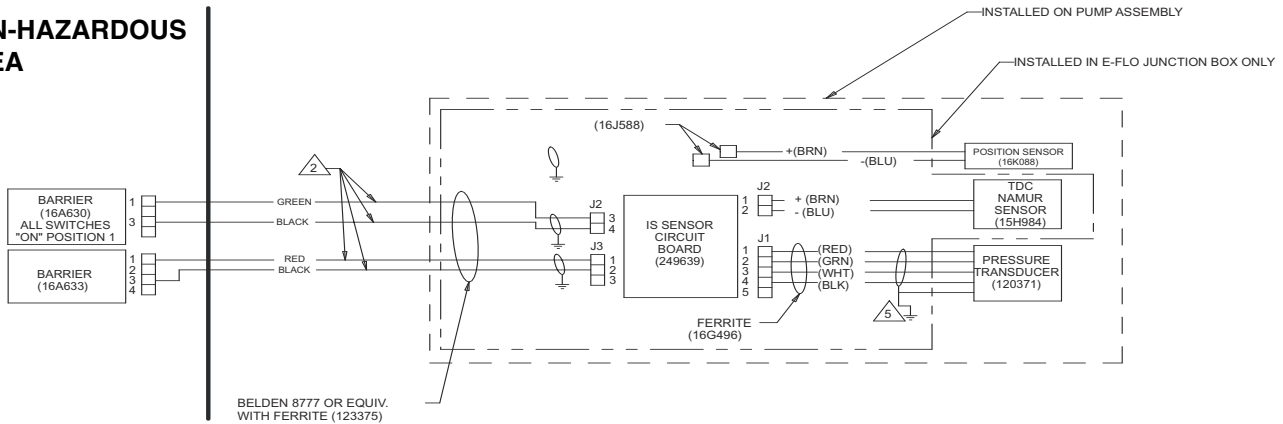

Fig. 2: System Wiring Schematic, Hazardous Location

DETAIL A

**HAZARDOUS (CLASSIFIED) LOCATION
CLASS I, DIV. 1, GROUP C & D, T3 (FM ONLY)
GROUP II, CATEGORY 2 - ZONE 1, GAS (ATEX ONLY)
CLASS I, DIV. 1, GROUP C & D T3 (CANADA)**

**NON-HAZARDOUS
AREA**



- 1 The installation must meet the requirements of the National Electric Code, Canadian Electrical Code Part I, Article 504, NFPA 70, and ANSI/ISA 12.06.01.
- 2 Individually shielded cables needed to ensure separation of sensor and transducer circuits.
- 3 The voltage (V_{max} or U_i), current (I_{max} or i_i), and power (P_i) must be equal to or greater than the voltage (V_{oc} , U_o , or V_t), current (I_{sc} , i_o , or I_t), and power (P_o or P_t) levels, which can be delivered by the associated apparatus. In addition, the maximum unprotected capacitance (C_i) and inductance (L_i) of the intrinsically safe apparatus, including interconnecting wiring, must be less than the capacitance (C_a) and inductance (L_a) which can be safely connected to the associated apparatus.
- 5 Land shield drain and foil to conductive strain relief.

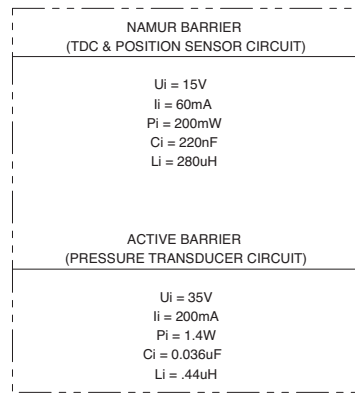

DETAIL B

HAZARDOUS AREA

SEE PAGE 13

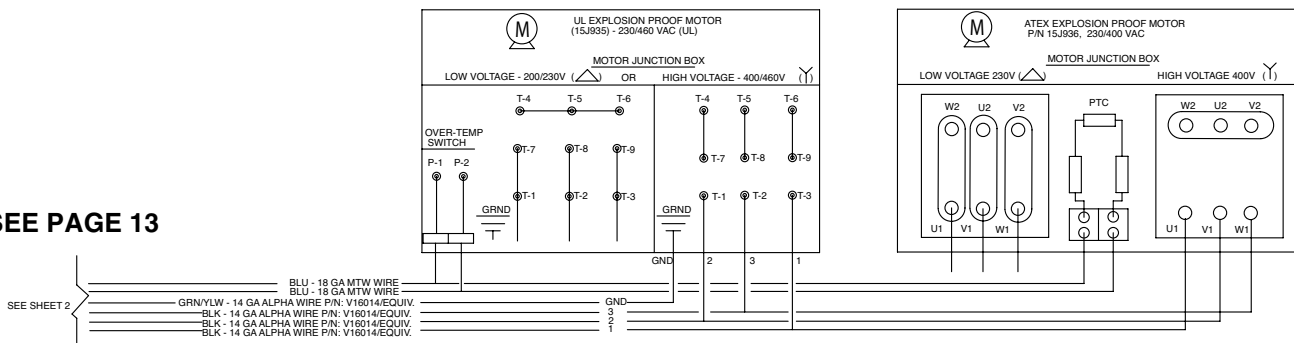

IS Control Drawing 288110

FIG. 3: System Wiring Schematic, Hazardous Location Detail Views

Repair

Fluid Section

NOTE: Complete kits are available to convert from one size lower to another. See the table below for available kits. Use all the new parts in the kit. The kits include two lowers, inlet/outlet manifolds, connecting hardware, and instruction manual 311611.

Kit Part No.	Lower Part No.	Description
289553	24F417	750 cc, Chrome
15J747	24F428	1000 cc, Chrome
15J748	24F436	1500 cc, Chrome
15J749	24F444	2000 cc, Chrome
16F420	24F418	750 cc, MaxLife
15J750	24F429	1000 cc, MaxLife
15J751	24F437	1500 cc, MaxLife
15J752	24F445	2000 cc, MaxLife

NOTE: Manifold Gasket Kit 15H878 is available to replace the sanitary gaskets at the inlet and outlet manifolds. The kit includes items 16, 41, 58, two 120631 PTFE Gaskets, and instruction sheet 406637.

Disassembly



1. Flush the pump, see page 9.
2. Jog the motor to bring the lower on the side being repaired to the bottom of its stroke. This provides access to the coupling nut (14).
3. Relieve pressure, page 9.
4. Remove the 2-piece shield (72, see FIG. 5) by inserting a screwdriver straight into the slot, and using it as a lever to release the tab. Repeat for all tabs. **Do not** use the screwdriver to pry the shields apart.

5. See FIG. 4. Place a 3/4 in. wrench on the slider piston (9) flats (just above the coupling nut), to keep the slider piston/connecting rod from turning when you are loosening the coupling nut (14). Orient the wrench so it is braced against one of the tie rods (3). Applying excessive force to the slider piston/connecting rod can shorten the life of the lower pin bearing.
6. Using a 1-5/8 in. open-end wrench, unscrew the coupling nut (14) from the slider piston (9) and let it slide down onto the pump piston rod. Be careful not to lose the collars (13).
7. Repeat steps 2-6 for the other lower.
8. Shut off electrical power and allow the unit to cool.

 Hold slider piston (9) flats with 3/4 in. wrench, and brace against tie rod (3).

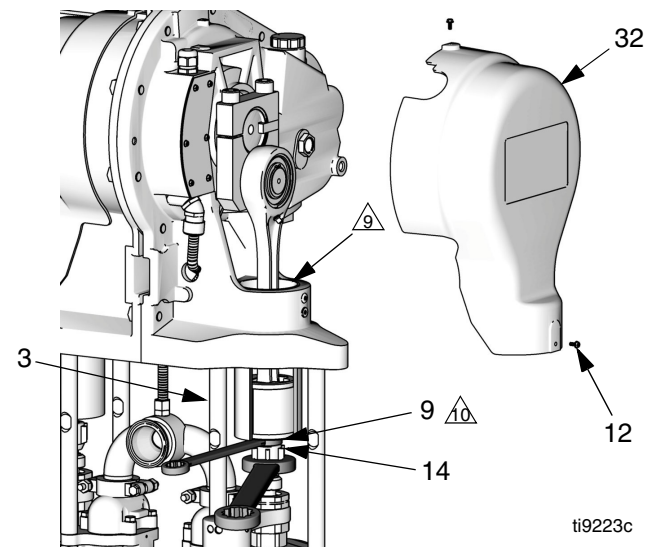





FIG. 4. Remove Coupling Nut

ti9223c

Repair

9. Disconnect the fluid inlet and outlet lines from the pump. Plug the ends to prevent fluid contamination.
10. See FIG. 5. *On pumps with a sensor circuit:* At the pump outlet manifold (17), loosen the nut (M) on the sensor conduit (44) and unscrew the adapter (42) from the manifold. Remove the transducer (25a) from the manifold port. Remove the existing o-ring (41) and discard.
11. Loosen the clamps (18) at the inlet and outlet manifolds (17). Remove the manifolds and gaskets (16).
12. Remove the coupling nut (14) and collars (13) from the piston rods (PR).
13. Unscrew the locknuts (15). Remove the lower (22). See your separate lower manual for repair instructions.

-  Torque to 50-60 ft-lb (68-80 N•m).
-  Torque to 75-80 ft-lb (102-108 N•m).
-  Torque to 15-20 ft-lb (21-27 N•m).
-  Apply lithium grease.

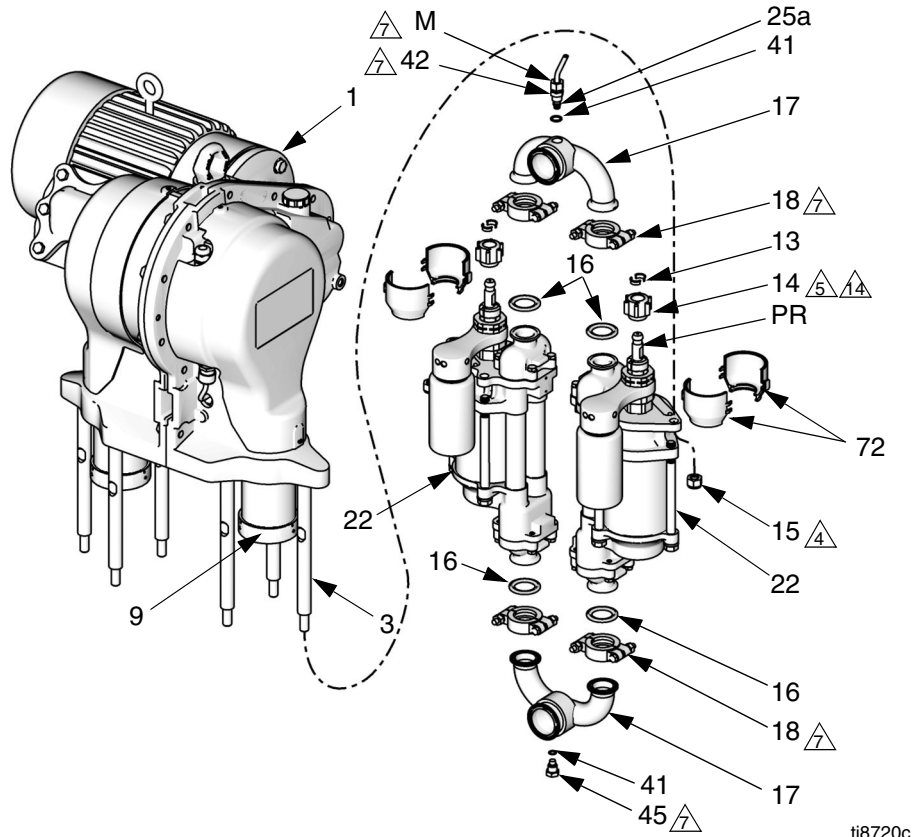

ti8720c

FIG. 5: Fluid Section

Reassembly

1. See FIG. 5. Install the coupling nut (14) on the lower's piston rod (PR).
 2. Orient the lower (22) to the gear reducer (GR) as shown. Position the lower on the tie rods (3). Screw the tie rod locknuts (15) onto the tie rods handtight.
 3. Assemble the inlet and outlet manifolds (17) to the lower, using new gaskets (16). Torque the clamps (18) to 15-20 ft-lb (21-27 N•m).
 4. Torque the locknuts (15) to 50-60 ft-lb (68-80 N•m).
 5. At the outlet manifold (17):
 - a. *On pumps with a sensor circuit:* Install a new black o-ring (41) on the transducer (25a). Insert the transducer into the outlet manifold (17). Torque the adapter (42) first, then the nut (M) to 15-20 ft-lb (21-27 N•m).
 - b. *On pumps without a sensor circuit:* Install a black o-ring (41) on the plug (45). Screw the plug into the outlet manifold (17) and torque to 15-20 ft-lb (21-27 N•m).
 6. Install a black o-ring (41) on the plug (45). Screw the plug into the inlet manifold (17) and torque to 15-20 ft-lb (21-27 N•m).
 7. Ensure that the collars (13) are in place in the coupling nut (14).
 8. Place a 3/4 in. wrench on the flats of the slider piston (9), to keep it from turning when you are tightening the coupling nut (14). Orient the wrench so it is braced against one of the tie rods (3) or the pump stand. Tighten the coupling nut (14) onto the slider piston (9) and torque to 75-80 ft-lb (102-108 N•m).
 9. Install the shields (72) by engaging the bottom lips with the groove in the wet-cup cap. Snap the two shields together.
 10. Turn on power and jog the motor to bring the other drive to the bottom of its stroke. Repeat procedure to connect the other lower.
- NOTE:** Update the drive software to reflect the change in size of the lowers. See manual 311596.
11. Flush and test the pump before reinstalling it in the system. Connect hoses and flush the pump. While it is pressurized, check for smooth operation and leaks. Adjust or repair as necessary before reinstalling in the system.

Slider Cylinder Rebuild Kit 15H874

NOTE: Slider Cylinder Rebuild Kit 15H874 includes parts to rebuild one slider cylinder assembly. Order two kits to rebuild both slider cylinder assemblies. Use all the new parts in the kit. The kit includes manual 311599.



1. Perform the **Disassembly** procedure on page 15.
2. Remove two screws (12) and the cover. FIG. 6 shows the cover (32) on the side opposite from the motor; the motor side cover is (21).
3. Remove the setscrew (31). Unscrew the slider cylinder (2) from the gear reducer (1).
4. Remove the bearings (8) from the slider piston (9).
5. Install the two new bearings (8) on the slider piston (9). The joints between the bearings must align with the pin hole (PH) in the slider piston.
6. Screw the slider cylinder (2) into the gear reducer (1). Torque to 15-20 ft-lb (21-27 N•m). Install the setscrew (31). Torque to 30-35 in-lb (3.4-3.9 N•m).
7. Install two screws (12) and the cover (32 is shown; use 21 on the motor side).
8. Perform the **Reassembly** procedure on page 17. Use the tie rod locknuts (15) included in the kit.
9. Return the pump to service.

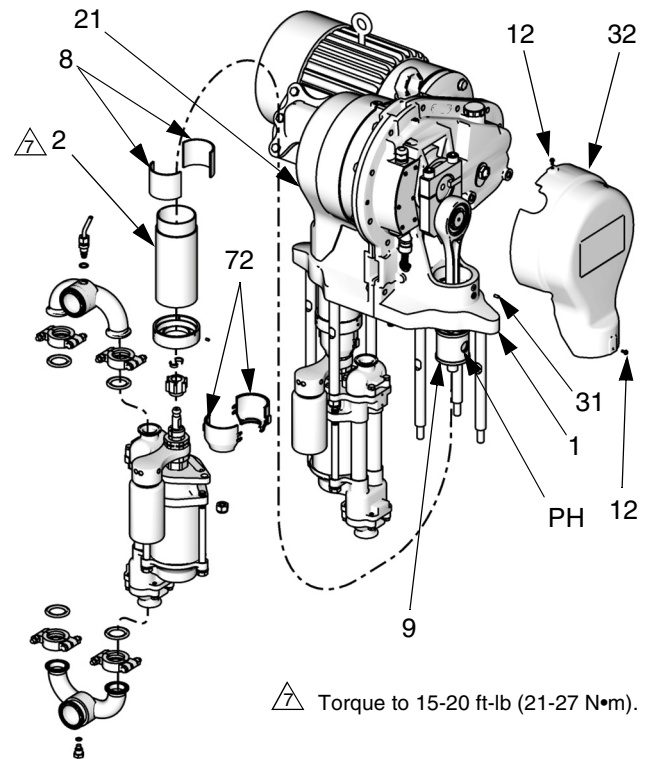

 Torque to 15-20 ft-lb (21-27 N•m).

ti8723c

FIG. 6. Slider Cylinder Kit

Slider Cylinder Collector Kit 247341

NOTE: Slider Cylinder Collector Kit 247341 includes parts to install two slider cylinder collectors. Use all the new parts in the kit. The kit includes manual 311607.



1. Perform the **Disassembly** procedure on page 15.
2. Jog motor to move slider piston (9) up, giving adequate clearance to fit collector (67) between slider cylinder and piston rod.
3. See FIG. 7. Position the collector (67) over the coupling nut (14) and drop it down onto the pump piston rod.

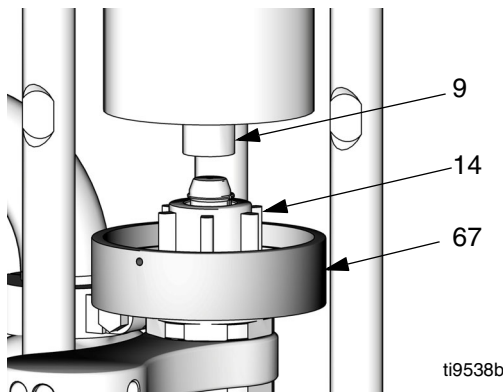

FIG. 7. Position Collector

4. Jog motor to move slider piston (9) to bottom of stroke, allowing reconnection of coupling nut (14).
5. Ensure that the collars (13) are in place in the coupling nut (14).
6. Place a 3/4 in. wrench on the flats of the slider piston (9), to keep it from turning when you are tightening the coupling nut (14). Orient the wrench so it is braced against one of the tie rods (3) or the stand. Tighten the coupling nut (14) onto the slider piston (9) and torque to 75-80 ft-lb (102-108 N•m).
7. See FIG. 8. Push the collector (67) up onto the bottom of the slider cylinder (2) so it seats securely. Install the three setscrews (68) finger-tight.

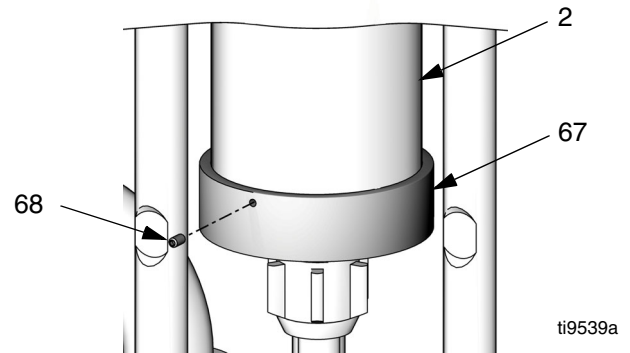

FIG. 8. Install Collector

8. Install the shields (72) by engaging the bottom lips with the groove in the wet-cup cap. Snap the two shields together.
9. Repeat for the other side.

Electrical Section

NOTE: Sensor Circuit Kit 24J305 is available to add the optional sensor circuit to a pump. Use all the new parts in the kit. See manual 311603.

Pressure Transducer Kit 15H876

NOTE: Pressure Transducer Kit 15H876 replaces the pressure transducer and the circuit board. Use all the new parts in the kit. The kit includes manual 311600.

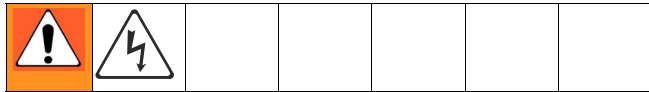

1. Jog the motor to bring the lower on the side opposite from the motor to the bottom of its stroke.
2. Relieve pressure, page 9.
3. Shut off electrical power to the unit.

4. Remove two screws (12) and the cover (32).
5. See FIG. 9. Remove six screws (12), the circuit board cover (34), and the gasket (33).
6. Disconnect the transducer cable (25a) from J1 on the circuit board (25c). See FIG. 9 and the **Electrical Diagrams**, page 12.
7. Disconnect the TDC cable (25b) from J2 on the circuit board (25c).
8. Disconnect the IS circuit field wire from J2 and J3.
9. Remove four screws (12) and the circuit board (25c).
10. Install the new circuit board (25c) using four screws (12).

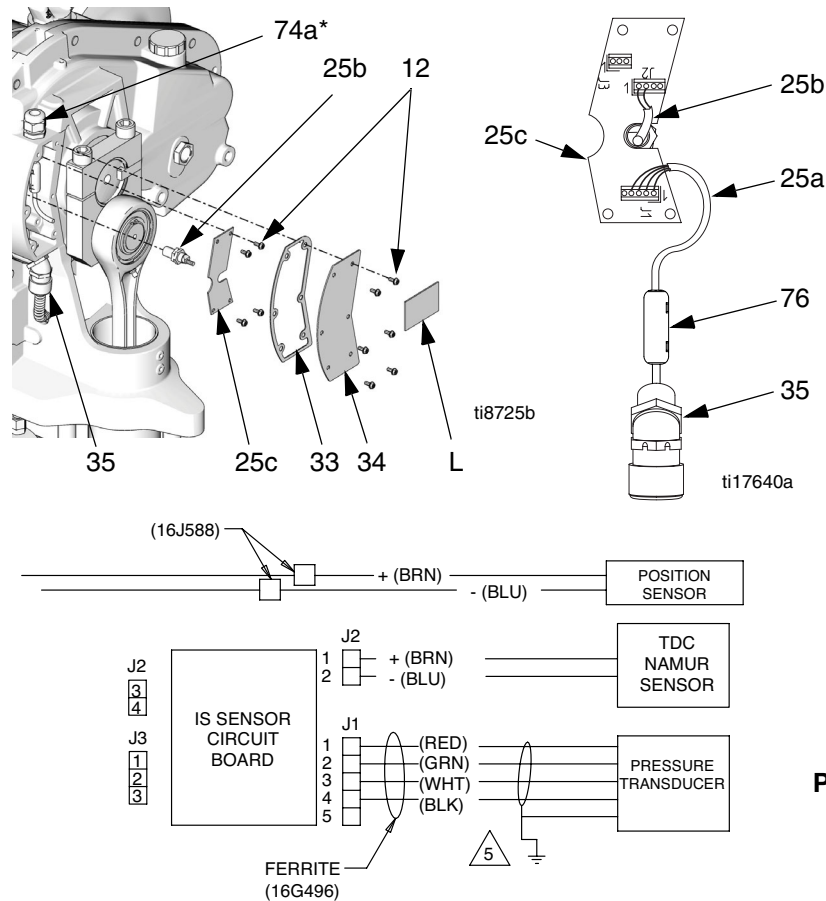

⚠ Land shield drain and foil to conductive strain relief.

FIG. 9. Circuit Board

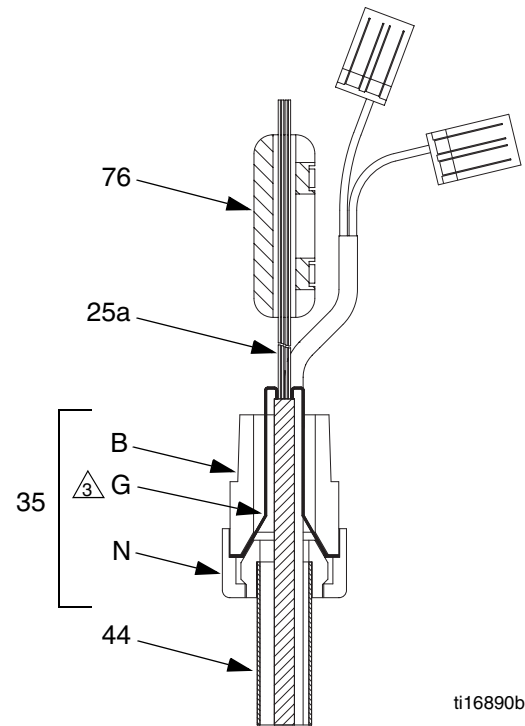

Pressure Transducer Grounding Schematic

⚠ Tighten nut (N) securely to ensure that the shield and drain wire (G) has firm metal-to-metal contact between the nut and bushing (B).

ti17644a

11. See FIG. 10. Loosen the nut (M) on the sensor conduit (44) and unscrew the adapter (42) from the transducer port (P). Remove the transducer (25a) from the port.
12. See FIG. 9. Loosen the nut (N) on the strain relief (35). Remove the ferrite (76). Pull the transducer cable (25a) out of the conduit (44).
13. See FIG. 10. Install one new black o-ring (41) and the new brass spacer (58) on the transducer (25a).
14. See FIG. 9. Ensure that the conductive strain relief (35) is screwed tightly into the housing, to ensure electrical continuity to the pump housing. Thread the transducer's cable (25a) through the adapter (42), short length of the conduit (44), and conductive strain relief (35). Reconnect the cable to J1 on the circuit board (25c). Install the ferrite (76) around the transducer leadwires.
15. See FIG. 9. Tighten the nut (N) on the conductive strain relief (35) securely to ensure that the shield and drain wire (G) has firm metal-to-metal contact between the nut and bushing (B).
16. See FIG. 10. Insert the transducer into the transducer port (P). Torque the adapter (42) first, then the nut (M) to 15-20 ft-lb (21-27 N•m).
17. See FIG. 9. Connect the TDC cable (25b) to J2 on the circuit board (25c).
18. Ensure that the conductive strain relief (74a) is screwed tightly into the housing. Units with a sensor circuit **must** use the conductive strain relief to ensure proper grounding of the IS field wire and shield.
19. Thread the IS field wire and shield through the conductive strain relief (74a) and connect it to J2 and J3. See FIG. 11 and the **Electrical Diagrams**, page 12.
20. See FIG. 11. Tighten the nut (N) on the conductive strain relief (74a) securely. Install the ferrite (77) on the field wire (F), not more than 2 in. (51 mm) from the bottom of the conductive strain relief (74a). Install ground wire to grounding screw in junction box.
21. Install the new gasket (33), the cover (34), and six screws (12).
22. Remove the old label (L) from the circuit board cover (34). Attach the new label (L) to the cover.

23. Calibrate the transducer, entering the calibration information found on the new label (L):
 - For systems using the Graco ACS Module, see the ACS manual 3A0006.
 - For non-ACS systems, see page 22.
24. Reinstall the cover (32) with two screws (12).

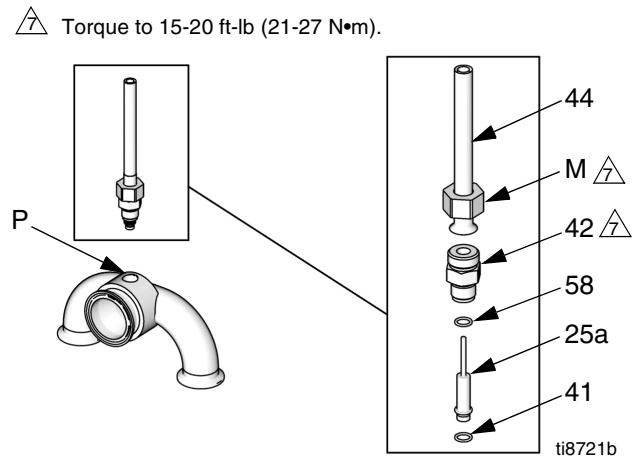

FIG. 10. Pressure Transducer

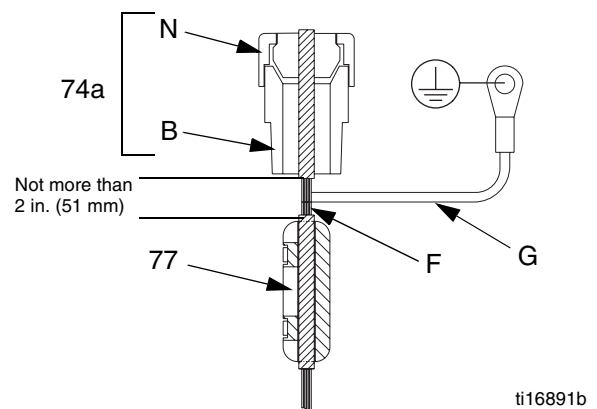

FIG. 11. IS Circuit Field Wire

Pressure Sensor Calibration Information (non-ACS systems)

NOTE: To calibrate the transducer in systems using the Graco ACS Module, see the ACS manual 3A0006.

Pressure sensor information (Pr 20.34, 20.35, and 20.36) for your system must be keyed into the Variable Frequency Drive before system start-up.

To prevent accidental change of pressure sensor calibration parameters, they are locked by Pr 20.16. To enter calibration parameters, perform the following steps:

- a. Set Pr 20.16 to 777, to unlock pressure sensor parameters.
- b. Enter calibration parameters Pr 20.34, 20.35, and 20.36.
- c. Set Pr 20.16 to 0 to lock pressure sensor parameters.

Calibration Parameters from the label:

Pr 20.34 – Zero Calibration

Pr 20.35 – Calibration Pressure

Pr 20.36 – High Calibration

Pressure Transducer Calibration Procedure (non-ACS systems)



E-Flo pressure sensor must be calibrated against an instrument grade High Precision Pressure Transducer, which should be installed near the E-Flo pressure sensor.

1. Ensure that the High Precision Pressure Transducer calibration is up to date.
2. Set Pr 20.16 to 777, to unlock pressure sensor parameters.
3. Calibrate Low Pressure Point as follows:
 - a. Ensure that system is not pressurized. Calibration instrument pressure reading should be 0 psi.
 - b. Use Keypad to navigate to Pr 20.33; monitor its reading for 5 – 10 seconds to determine its average value. Make a record of it.

- c. Navigate to Pr 20.34 and enter the recorded average value of Pr 20.33.

4. Calibrate the High Pressure Point as follows:

- a. Pressurize the system to 250 – 275 psi.

						
Do not exceed pressure rating of the system! If system is rated to a pressure lower than 250 psi, use maximum allowable rated pressure. Refer to Operation Manual 311593.						

- b. Keep the system pressurized and ensure that pressure does not fluctuate.
 - c. Take a pressure reading from the calibration instrument and make a record of it.
 - d. Navigate to Pr 20.35 and enter the recorded system pressure.
 - e. Navigate to Pr 20.33; monitor its reading for 5-10 seconds to determine its average value. Make a record of it.
 - f. Navigate to Pr 20.36 and enter the recorded value of Pr 20.33.

5. Set Pr 20.16 to 0 to lock pressure sensor parameters.

6. Verify pressure calibration.

- a. Relieve system pressure.
 - b. Navigate to Pr 20.31 and verify that its reading is within the range of 0-3 psi.
 - c. Pressurize the system to about 100 psi. Verify that reading of Pr 20.31 is within +/- 2.5 psi of the system pressure.
 - d. Pressurize system to about 250 psi. Verify that reading of Pr 20.31 is within +/- 2.5 psi of the system pressure.

TDC Sensor Kit 15H877

NOTE: TDC Sensor Kit 15H877 replaces the TDC sensor. Use all the new parts in the kit. The kit includes manual 311601.



1. Jog the motor to bring the lower on the side opposite from the motor to the bottom of its stroke.
 2. Relieve pressure, page 9.
 3. Shut off electrical power to the unit.
 4. Remove two screws (12) and the cover (32).
 5. See FIG. 12. Remove six screws (12), the circuit board cover (34), and the gasket (33).
 6. Disconnect the transducer cable (25a) from J1 on the circuit board (25c). See FIG. 9, page 20.
 7. Disconnect the TDC cable (25b) from J2 on the circuit board (25c).
 8. Disconnect the IS circuit field wire from J2 and J3. See the **Electrical Diagrams**, page 12.
 9. See FIG. 12. Remove four screws (12) and the circuit board (25c).
 10. Unscrew the TDC sensor (25b) from the gear housing.
 11. Apply pipe sealant and screw the TDC sensor (25b) into the gear housing. Torque to 66-78 in-lb (7.4-8.8 N•m).
- NOTE:** TDC sensor nuts are locked in place to ensure correct positioning. Do not adjust.
12. Install the circuit board (25c) using four screws (12).

13. Reconnect the TDC cable (25b) to J2 on the circuit board (25c).
14. Reconnect the transducer cable (25a) to J1 on the circuit board (25c).
15. Reconnect the IS circuit field wire to J2 and J3. See the **Electrical Diagrams**, page 12.
16. Install the new gasket (33), the cover (34), and six screws (12).
17. Reinstall the cover (32) with two screws (12).

 Torque to 66-78 in-lb (7.4-8.8 N•m).

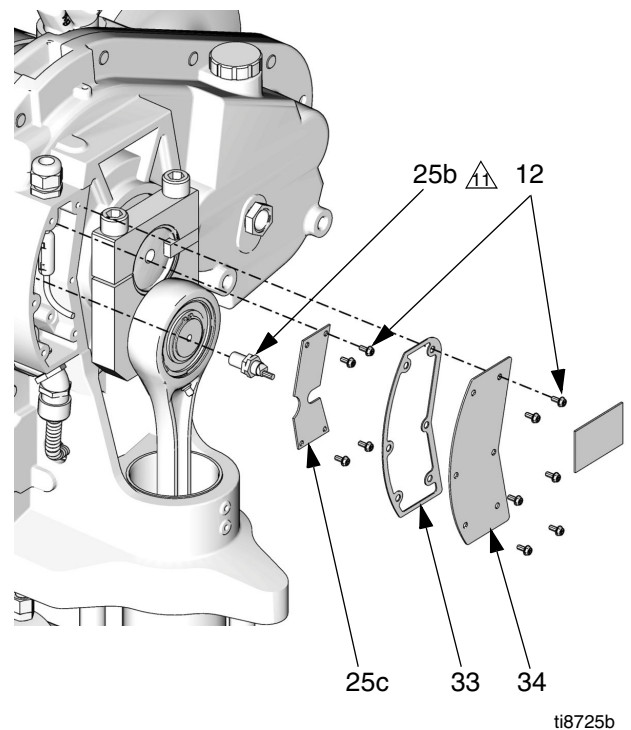

FIG. 12. TDC Sensor

Position Sensor

NOTE: The Position Sensor (80) measures motor position by detecting holes in the motor coupler (28). The sensor is available separately (see **Parts** on page 45), or as part of the Sensor Circuit Kit 24J305 (see manual 311603).



1. Jog the motor to bring the lower on the side opposite from the motor to the bottom of its stroke.
2. Relieve pressure, page 9.
3. Shut off electrical power to the unit.
4. Remove two screws (12) and the cover (32).
5. See FIG. 12. Remove six screws (12), the circuit board cover (34), and the gasket (33).
6. Disconnect the position sensor wires and the IS circuit field wires from the two terminal blocks (46). Retain the terminal blocks. See the **Electrical Diagrams**, page 12.
7. See FIG. 9 on page 20. Loosen the nut (N) on the strain relief (35).
8. See FIG. 13. Loosen the nut (M) on the conduit (44) and unscrew the sleeve (79) from the position sensor adapter (78). Remove the position sensor (80), pulling its wires through the conduit (44).

NOTE: If the adapter (78) was removed, apply thread lubricant and torque to 75-80 ft-lb (102-108 N•m).

9. Install the new position sensor (80) into the adapter (78) and secure with the sleeve (79).

NOTE: The Position Sensor nuts are locked in place to ensure correct positioning. Do not adjust.

10. Thread the position sensor wires through the long length of the conduit (44) into the circuit board cavity. Connect a terminal block (46) to each wire. Reconnect the IS circuit field wires to the terminal blocks. See the **Electrical Diagrams**, page 12.
11. Secure the conduit (44) to the position sensor sleeve (79) with the nut (M). Torque to 15-20 ft-lb (21-27 N•m).
12. See FIG. 13. Tighten the nut (N) on the conductive strain relief (35) securely to ensure that the shield and drain wire (G) has firm metal-to-metal contact between the nut and bushing (B).
13. Install the new gasket (33), the cover (34), and six screws (12).
14. Reinstall the cover (32) with two screws (12).

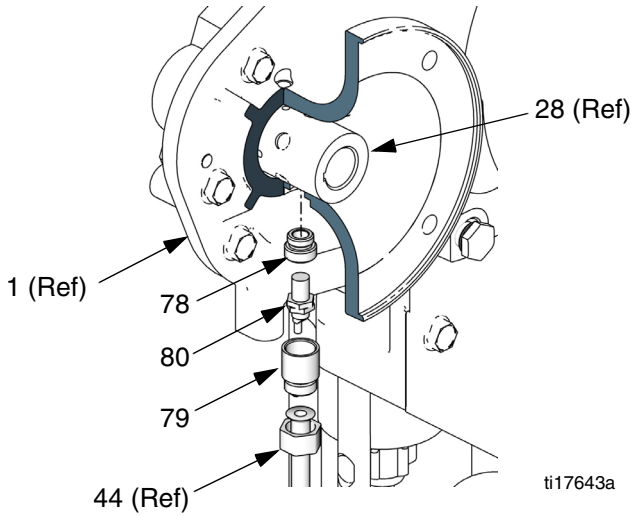

Position Sensor Parts and Location

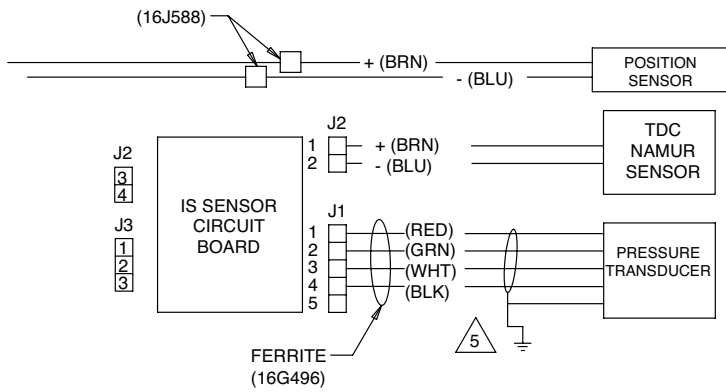

5 Land shield drain and foil to conductive strain relief.

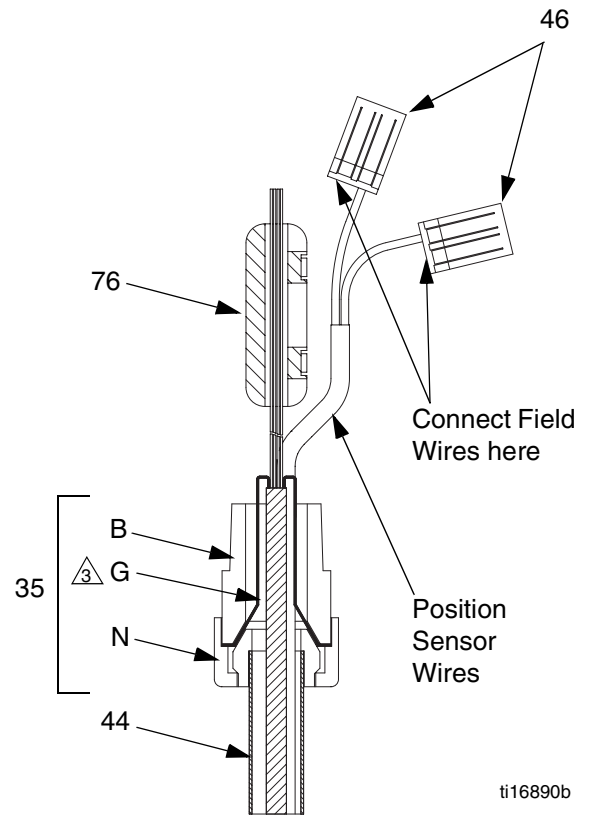

Position Sensor Wires and Terminals

3 Tighten nut (N) securely to ensure that the shield and drain wire (G) has firm metal-to-metal contact between the nut and bushing (B).

ti17644a

FIG. 13. Position Sensor

Drive Section

Slider Bearing Kit 15H882

NOTE: Slider Bearing Kit 15H882 includes parts to rebuild both slider bearing assemblies. Use all the new parts in the kit. The kit includes manual 311616.



1. Jog the motor to bring the pump on the side being repaired to the bottom of its stroke. This provides access to the coupling nut (14).
2. Relieve pressure, page 9.
3. Shut off electrical power to the unit.
4. Remove two screws (12) and the cover. FIG. 14 shows the cover (32) on the side opposite from the motor; the motor side cover is (21).

9 Place clean rag over slider cylinder (2).

10 Hold slider piston (9) flats with 3/4 in. wrench, and brace against tie rod (3).

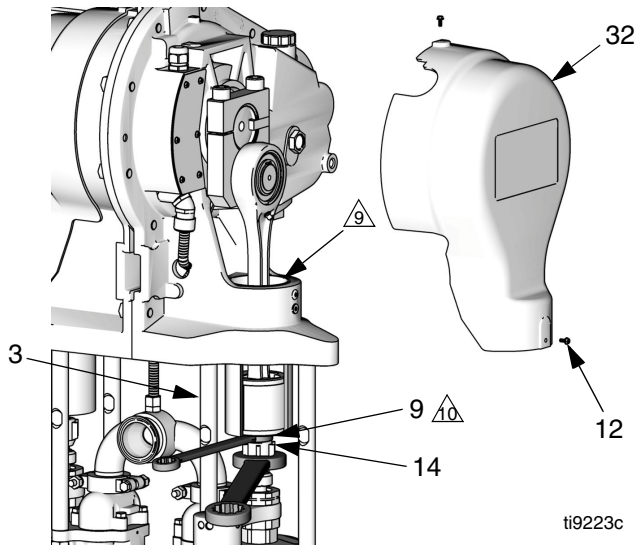

FIG. 14. Remove Coupling Nut

5. Place a clean rag over the top of the slider cylinder (2) to prevent debris from falling into the slider assembly during disassembly.

6. Remove the 2-piece shield (72) by inserting a screwdriver straight into the slot, and using it as a lever to release the tab. Repeat for all tabs. **Do not** use the screwdriver to pry the shields apart.
7. Place a 3/4 in. wrench on the slider piston (9) flats (just above the coupling nut), to keep the slider piston/connecting rod from turning when you are loosening the coupling nut (14). Orient the wrench so it is braced against one of the tie rods (3). Applying excessive force to the slider piston/connecting rod can shorten the life of the lower pin bearing.
8. Using a 1-5/8 in. open-end wrench, unscrew the coupling nut (14) from the slider piston (9) and let it slide down onto the pump piston rod. Be careful not to lose the collars (13).
9. See FIG. 15. Using a 1/2 in. hex driver, unscrew the two cap screws (5). Remove the crank arm cap (38) and key (39). If necessary, use a plastic hammer to break these parts loose.

9 Place clean rag over slider cylinder (2).

12 Apply antiseize lubricant (LPS®-04110 or equivalent) to screw (5) threads. Torque key-side screw to 210-230 ft-lb (283-310 N•m) first, then torque gap side screw to 210-230 ft-lb (283-310 N•m). Torque screws an additional 2-3 times each, or until they stop turning when torqued to 210-230 ft-lb (283-310 N•m).

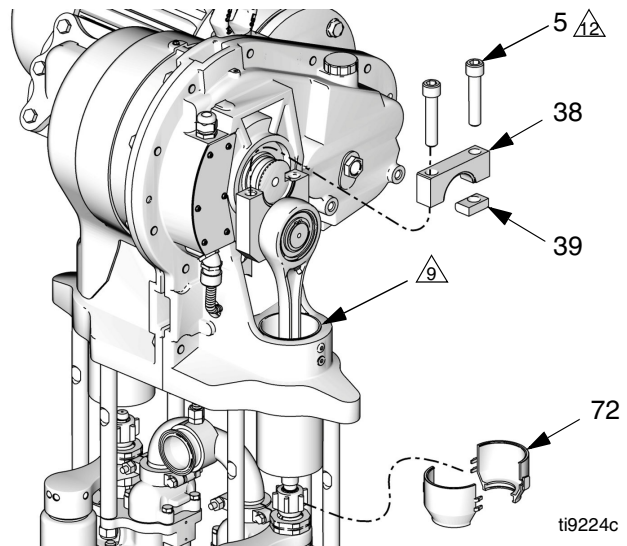

FIG. 15. Remove Crank Arm Cap

10. See FIG. 16. Rotate the crank arm (4) to allow it to be removed from the output shaft (OS).
11. Pull the crank arm/connecting rod/slider piston assembly (CR) up and out of the cylinder.
12. Remove the old bearings (8).

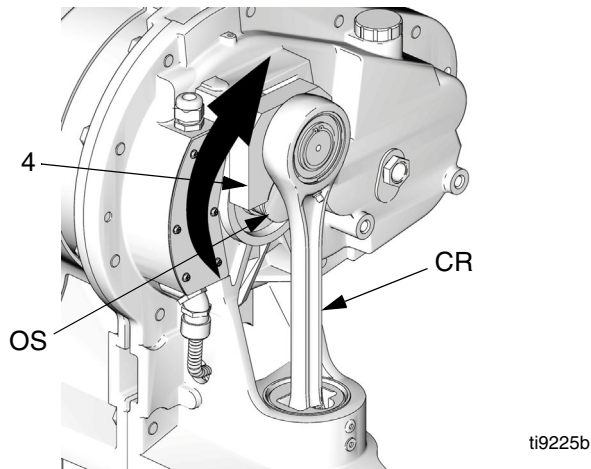

FIG. 16. Rotate Crank Arm

13. See FIG. 17. Install the two new bearings (8) on the slider piston (9). The joints between the bearings must align with the pin hole (PH) in the slider piston.

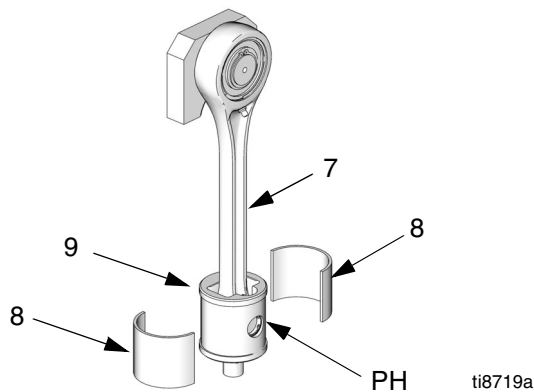

FIG. 17. Slider Bearings

14. Slide the piston (9) and connecting rod (7) into the cylinder (2).
15. Position the crank arm (4) to engage the output shaft (OS), and rotate it to the bottom of the output shaft.
16. Place a clean rag over the top of the slider cylinder (2) to prevent debris from falling into the slider assembly during reassembly.
17. See FIG. 15. Apply antiseize lubricant (LPS[®]-04110 or equivalent) to the threads of the cap screws (5). Install the key (39), crank arm cap (38), and cap screws (5), oriented as shown. While the gap-side screw is still loose, torque the key-side screw to 210-230 ft-lb (283-310 N•m). Then torque the gap-side screw to 210-230 ft-lb (283-310 N•m). Torque screws an additional 2-3 times each, or until they stop turning when torqued to 210-230 ft-lb (283-310 N•m).
18. Ensure that the collars (13) are in place in the coupling nut (14).
19. Place a 3/4 in. wrench on the flats of the slider piston (9), to keep it from turning when you are tightening the coupling nut (14). Orient the wrench so it is braced against one of the tie rods (3) or the pump stand. Tighten the coupling nut (14) onto the slider piston (9) and torque to 75-80 ft-lb (102-108 N•m).
20. Install the shields (72) by engaging the bottom lips with the groove in the wet-cup cap. Snap the two shields together.
21. Remove the rag. Reinstall the cover (32 or 21) and screws (12).
22. Repeat for the other side.

Drive Linkage Rebuild Kit 15H873

NOTE: Drive Linkage Rebuild Kit 15H873 includes parts to rebuild one drive linkage assembly. Order two kits to rebuild both drive linkage assemblies. Use all the new parts in the kit. The kit includes manual 311598.

NOTE: Replace the wrist pin bearings (7a) in the connecting rod annually. Wrist Pin Replacement Kit 255216 includes parts to replace the wrist pin bearings on both drive linkage assemblies. Use all the new parts in the kit. The kit includes manual 311609.

6. Every 6 months, lubricate the wrist pin bearing (7a) on the connecting rod with 1 shot (1 cc) of 107411 Grease or equivalent, using grease zerk (GZ). The top bearing is prelubricated and does not require grease at installation.
7. Reconnect the drive linkage. See steps 13-21 on page 27.
8. Repeat for the other side.

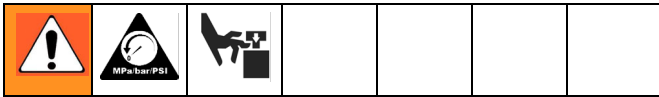

1. Jog the motor to bring the pump on the side being repaired to the bottom of its stroke. This provides access to the coupling nut (14).
2. Relieve pressure, page 9.
3. Shut off electrical power to the unit.
4. Disconnect the drive linkage. See steps 4-12 on pages 26-27.
5. See FIG. 18. Orient the new connecting rod (7) and slider piston (9) as shown. Assemble the crank arm (4), retaining rings (6), pin (10), and retaining ring (11).

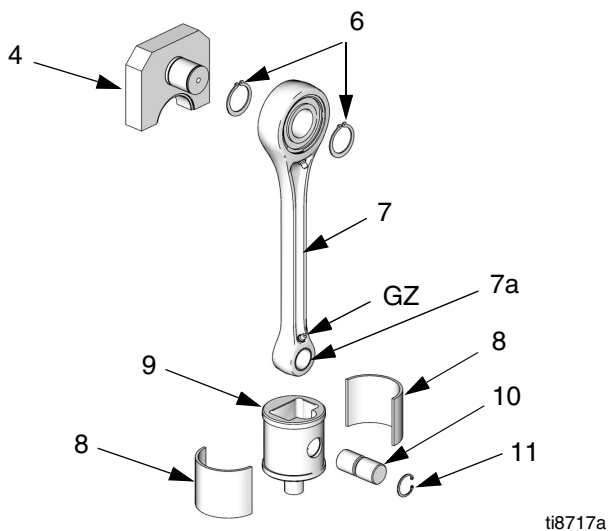

FIG. 18. Drive Linkage Assembly

Crank Arm Kit 15H883

NOTE: Crank Arm Kit 15H883 is available. Order two kits to rebuild both crank arm assemblies. Use all the new parts in the kit. The kit includes manual 311604.

NOTE: Crank Arm Cover Kit 15H378 is available to replace both crank arm covers (21, 32). Use all the new parts in the kit.



1. Jog the motor to bring the pump on the side being repaired to the bottom of its stroke. This provides access to the coupling nut (14).
2. Relieve pressure, page 9.
3. Shut off electrical power to the unit.
4. Disconnect the crank arm. See steps 4-11 on pages 26-27.
5. See FIG. 19. Remove the outer retaining ring (6) securing the crank arm (4) to the connecting rod (7). Slide the crank arm shaft out of the connecting rod.
6. Assemble the crank arm (4) to the connecting rod (7) with two retaining rings (6), oriented as shown.
7. Ensure that the joints between the bearings (8) align with the pin hole (PH) in the slider piston. See FIG. 17 on page 27.
8. Reconnect the crank arm assembly. See steps 14-21 on page 27.
9. Repeat for the other side.

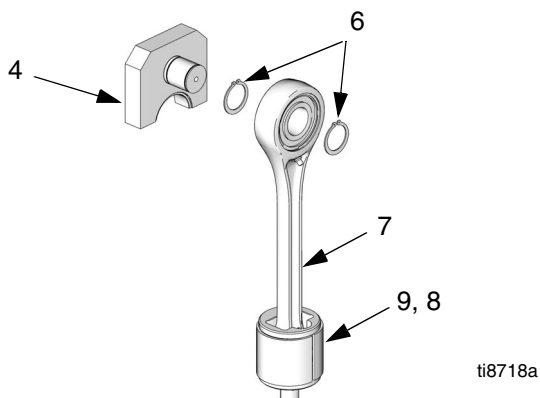
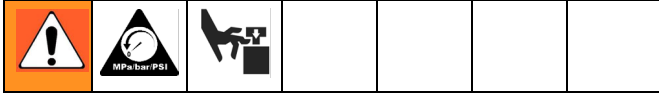

FIG. 19. Crank Arm and Connecting Rod

Motor/Gear Reducer

Motor Removal



1. Relieve pressure, page 9.
2. Shut off electrical power to the unit.

NOTE: See FIG. 20 for all NEMA 182/184 TC Frame electric motors. See FIG. 21 for IEC 112M/B5 and 100L/B5 Frame electric motors.

3. While one person supports the motor (19), remove the screws (37). Pull the motor away from the gear reducer.

NOTE: If the motor does not come off the gear reducer easily, **stop immediately** and go to **Motor/Coupler is Difficult to Remove**, page 31.

4. See FIG. 22. Loosen both setscrews (31). Insert the coupler removal tool (T) into the coupler (28). Turn nut clockwise until tight, then pull the coupler off the gear reducer input shaft (105) by turning hex-head screw (HS) clockwise.

NOTE: A faint clicking may be heard while the motor is running. This is normal and is due to necessary clearances between the coupler (28), motor shaft, and motor key. If the intensity increases significantly over time, it could indicate the coupler is wearing and should be replaced. **Do not open the gear reducer. Opening the gear reducer voids the warranty.** The gear reducer is not field serviceable beyond the maintenance recommended in this manual.

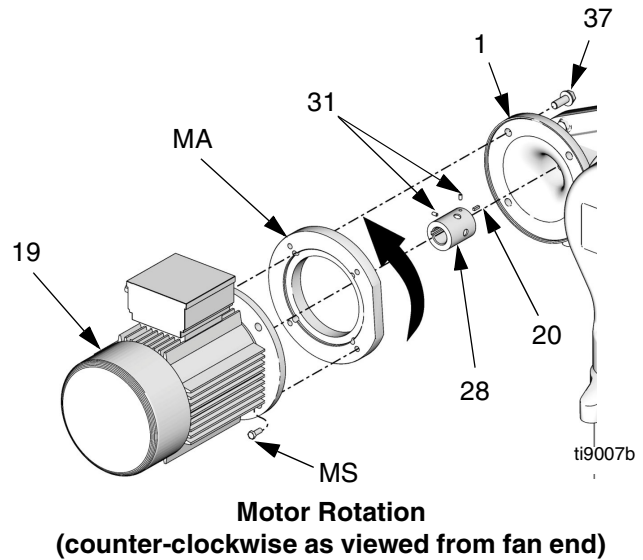

FIG. 21. IEC 112M/B5 and 100L/B5 Frame Electric Motors

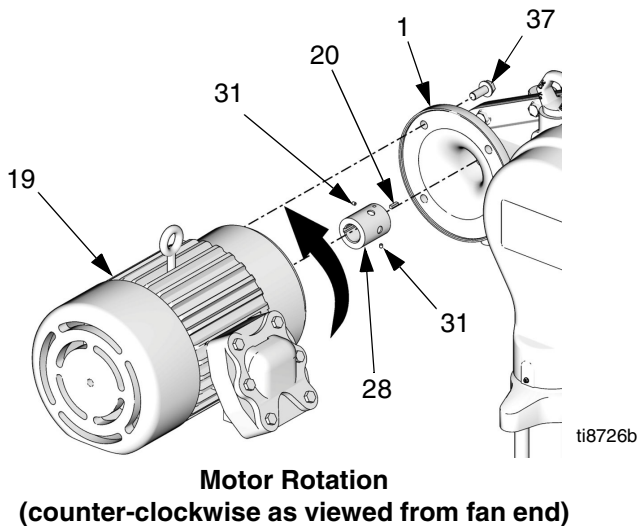

FIG. 20. All NEMA 182/184 TC Frame Electric Motors

Motor/Coupler is Difficult to Remove

NOTE: Use this procedure only if, after performing steps 1-3 on page 30, the motor does not come off the gear reducer easily.

NOTE: During the following procedure, if the coupler becomes separated from the motor shaft but remains stuck on the input shaft, use the 15J827 coupler removal tool (T) as shown in FIG. 22.

1. Use a mechanical lift and straps capable of supporting a minimum of 100 lb (45 kg) to support the motor. Pull the supported motor away from the gear reducer in a straight line, while at the same time forcing the back of the motor up and down by hand to loosen the motor shaft from the input shaft.
2. Continuing to support the motor, use a large flat-head screwdriver to pry the motor flange away from the gear reducer flange. *If the motor does not pull away in a straight line, stop immediately* and go to step 3.
3. Remove both setscrews from the coupler. If necessary, manually rotate the fan at the rear of the motor to access the setscrews.
4. Spray a generous amount of penetrating lubricant (such as Liquid Wrench® L112 or equivalent) in the setscrew holes. Allow time for the lubricant to penetrate around the shaft. Repeat steps 1 and 2.
5. If the motor still will not separate from the gear reducer, repeat step 4 as necessary. If the motor separates but the coupler is still seized on the motor shaft, go to step 6.
6. Ensure that the motor fan cage is in place. Gently tip the motor on end, with the fan cage down. Spray a generous amount of penetrating lubricant into the open end of the input shaft bore. Allow time for the lubricant to penetrate downward around the motor shaft. Using a pliers, pull the coupler off the shaft. Repeat application of lubricant until the coupler can be easily removed with a pliers.

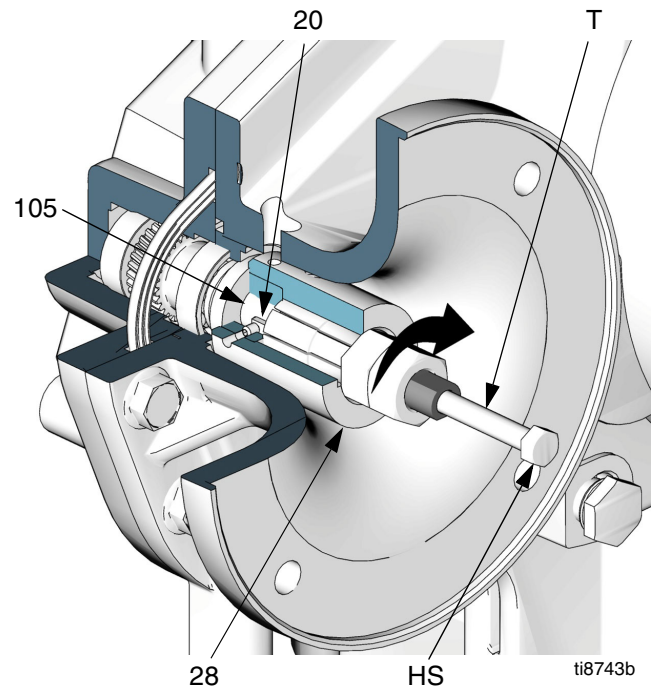

Fig. 22. Motor Coupler Removal

Motor Installation

NOTE: A NEMA 182/184 TC Frame is required to mate with gear reducer. If the pump is purchased without a motor you must order a kit to mate with the gear reducer. See TABLE 1.

Table 1: Motor Adapter Kits

Kit No.	Description
16C487	Coupler Kit for NEMA 182-184 TC Frame 3 or 5 HP motors. Includes 2.25 in. (57.2 mm) key★. See manual 311605.
15H880	Coupler Kit for NEMA 182/184 TC Frame 3 or 5 HP motors. Includes 1.75 in. (44.5 mm) key★. See manual 311605.
24E453	Mounts IEC 112M/B5 or 100L/B5 Frame 3 or 5 HP motor to gear reducer★. See manual 311605.
<p>★NOTE: All kits include the 0.62 in. (15.7 mm) key (120376). Some kits include an additional motor shaft key. Measure the length of the motor keyway to determine the correct key length. Key length should be at least 90% of keyway length.</p>	

1. After removing the old coupler, thoroughly clean the input shaft and motor shaft, removing any debris. This ensures proper clearance and fit for the new coupler.

NOTE: Do not reuse the old keys or setscrews. Use only the parts supplied with the new coupler kit.

2. See FIG. 23. Assemble the key (20) in the input shaft (105) keyway. Assemble the two setscrews (31) in the coupler (28), ensuring that they do not encroach on the keyway or the input shaft bore of the coupler.
3. Slide the coupler into the gear reducer so the key and input shaft mate with the coupler. Slide on until coupler bottoms out on the tapered step of the shaft.

NOTICE

Ensure that neither the input key (20) or the end of the coupler (28) motor shaft bore extend past the end of the input shaft (105). This could cause the motor shaft to bottom out on the coupler, causing excessive heat and bearing damage.

4. Tighten setscrews to 66-78 in-lb (7.4-8.8 N•m). Apply antiseize lubricant (LPS[®]-04110 or equivalent) to bore of coupler.

 Apply antiseize lubricant (LPS[®]-04110 or equivalent) to bore of coupler (28).

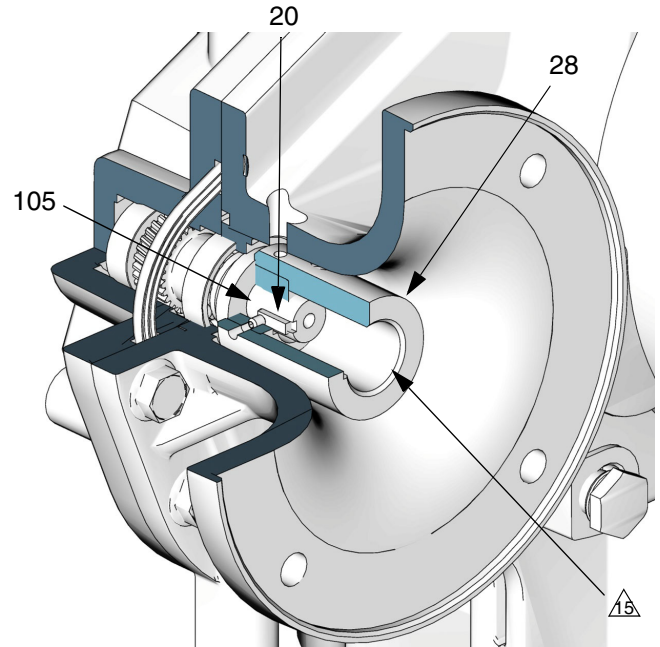

ti8913b

FIG. 23. Motor Coupler Installation

NOTE: When installing an IEC 112M/B5 or 100L/B5 Frame electric motor, ensure that the motor adapter (MA) and screws (MS) are in place before mounting the motor on the gear reducer. See FIG. 21.

NOTICE

When installing the electric motor, always ensure that the motor shaft key cannot move out of position. If the key works loose it could cause excessive heat and equipment damage.

5. Lift the motor (19) into position. Align the key (36, FIG. 28) on the motor shaft with the mating slot of the motor coupler, and the four mounting holes with the holes in the gear reducer (1). Slide the motor into place.
6. While one person supports the motor (19), install the screws (37). Torque to 75-80 ft-lb (102-108 N•m).

Gear Reducer Seal Kit 15H871

NOTE: Gear Reducer Seal Kit 15H871 and Output Shaft Seal Tool Kit 15J926 are available. Use all the new parts in the kit. The kits include manual 311597.

NOTE: Do not open the gear reducer. Opening the gear reducer voids the warranty. The gear reducer is not field serviceable beyond the maintenance recommended in this manual.

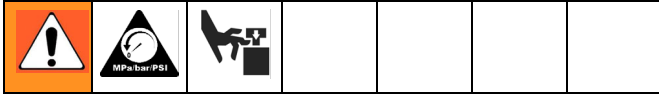

1. Jog the motor to bring the motor-side pump to the bottom of its stroke.

NOTE: Repair the motor side seals first, as follows.

2. Relieve pressure, page 9.
3. Shut off electrical power to the unit.
4. Remove the motor and coupler, see page 30.
5. Remove four screws (12) and both covers (21, 32).
6. See FIG. 24. On the motor side of the gear reducer, unscrew the oil drain plug (118) with gasket. Pierce the input seal (109) with a hardened sheet metal screw and pull it out.

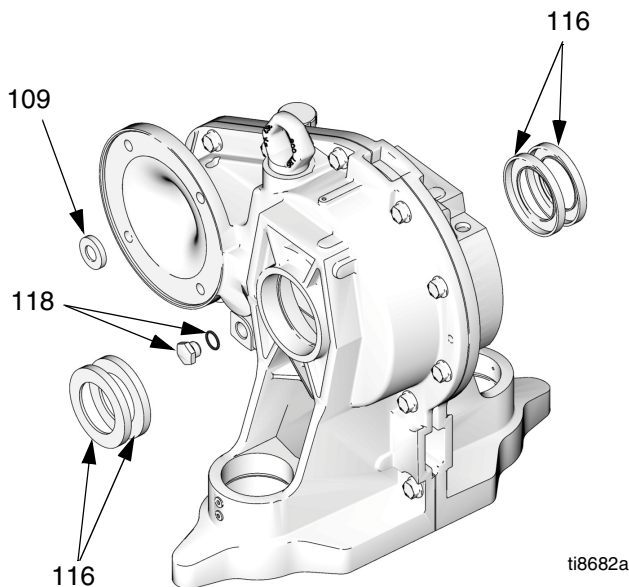

FIG. 24. Gear Reducer Seals

7. Place tape over the input shaft keyway, to prevent damage to the new seal. Pack the input shaft seal cavity with Part No. 107411 Grease. Install the input seal (109) with the lip facing in, until the seal contacts the shoulder of the gear reducer housing. Remove the tape.
8. Ensure that the included gasket is on the oil drain plug (118), then screw the plug into the gear reducer. Tighten to 25 ft-lb (34 N•m).
9. Disconnect the crank arm. See steps 5-10 on page 26.
10. Remove the two output seals (116) as follows:
 - a. See FIG. 25. Place the tool (C) onto the output shaft (OS). Turn the tool 90°. Install and tighten the two 0.5 in. (13 mm) screws (G) to lock the tool in place.
 - b. Drill 1/8 in. (3 mm) diameter (maximum) pilot holes in the seals (116), using the holes for the sheet metal screws (D) as a template. Install the sheet metal screws (D) through the tool and into the seals (116).
 - c. Tighten screws (D) evenly to pull both seals out.

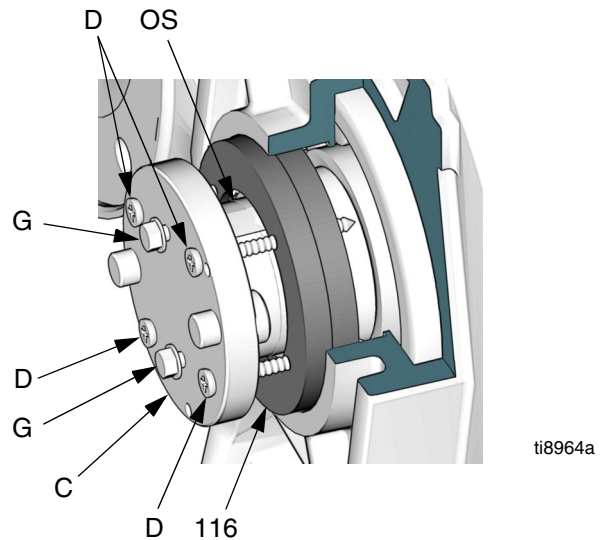





FIG. 25. Remove Output Shaft Seals

11. Install the two output seals (116) as follows:
 - a. Place tape over the output shaft keyway, to prevent damage to the new seals. Pack the output shaft seal cavity with Part No. 107411 Grease.
 - b. See FIG. 26. Push **one** output seal (116) onto the output shaft (OS), with the lips facing in.
 - c. Remove the sheet metal screws from the tool (C). Place the tool (C) onto the output shaft (OS), fitting one screw (A) into the slot of the shaft. Turn the tool 90°. Tighten the screws (G) to lock it onto the shaft.
 - d. Place the installation tool (E) against the seal (116) as shown.
 - e. Install the tool cover (F) and evenly tighten the screws (J) to seat the seal on the output shaft (OS).
 - f. Remove the tools. Take three measurements 120° apart, from the surface of the seal to the face of the housing (H). The three measurements must be within .020 in. (0.5 mm). If not, repeat steps c through e.
 - g. Repeat for the second seal (116). Remove the tape.
12. Reconnect the crank arm. See steps 14-17 on page 27.
13. Reinstall the coupler and motor, see page 33.
14. Turn on electrical power to the unit.
15. Jog the motor to bring the lower on the side opposite from the motor to the bottom of its stroke.
16. Shut off electrical power to the unit.
17. Repeat steps 9-12 to replace the output seals on the side opposite from the motor.
18. Reinstall the covers (21, 32) and screws (12).
19. Add 2 quarts of gear oil, Part No. 288414.

 Pack cavity with grease before installing seal.

 Insert until 109 contacts shoulder.

 Insert until 116 contacts shoulder.

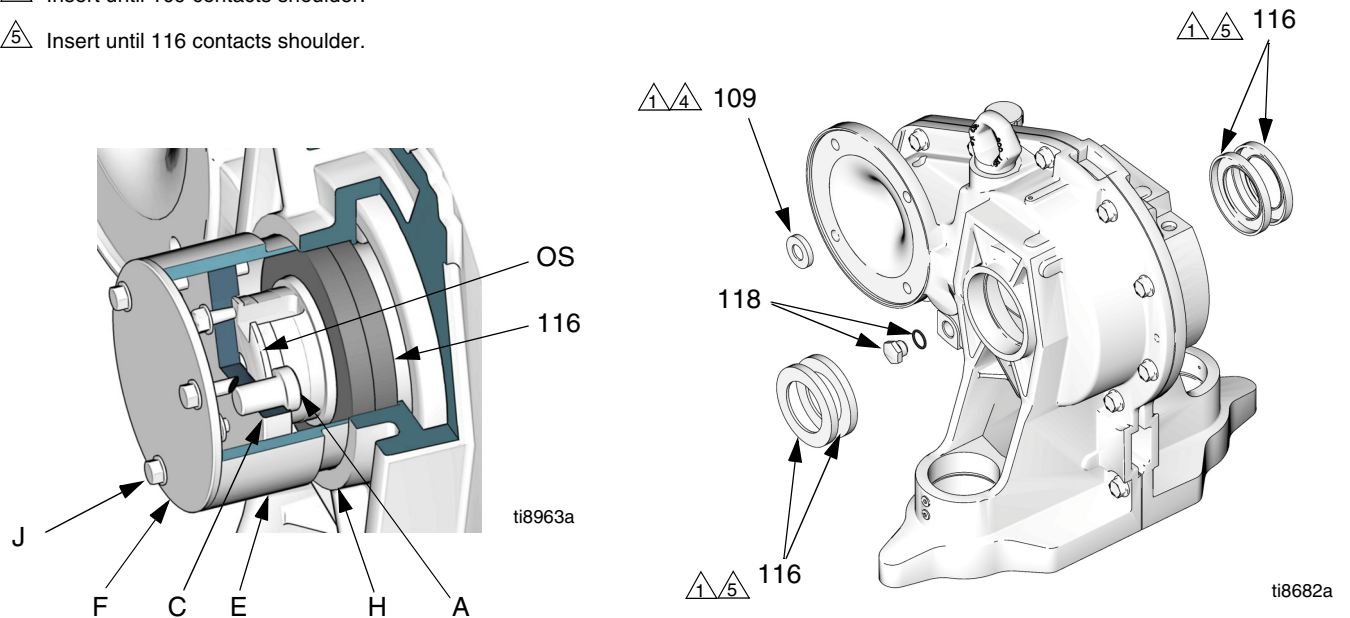

FIG. 26: Gear Reducer Seal Kit

Gear Reducer Replacement Kit

Disassembly

NOTE: The Gear Reducer Kit is available to replace the entire gear reducer. Use all the new parts in the kit. Order Kit 15H886 for E-Flo 2000/3000/4000 Pumps or Kit 289550 for E-Flo 1500 Pumps. The kit includes manual 311615.

NOTE: Do not open the gear reducer. Opening the gear reducer voids the warranty. The gear reducer is not field serviceable beyond the maintenance recommended in this manual.

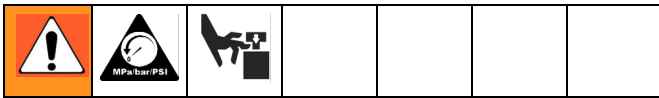

1. Jog the motor to bring the lower on the side opposite from the motor to the bottom of its stroke. This provides access to the coupling nut (14).
2. Relieve pressure, page 9.
3. Shut off electrical power to the unit.
4. See FIG. 28. Remove the shields (72). Disconnect the drive linkage. See steps 4-11 on pages 26-27.
5. Turn on power and jog the motor to bring the motor side lower to the bottom of its stroke.
6. Shut off electrical power to the unit. Repeat the procedure for the motor side lower.
7. Disconnect the fluid inlet and outlet lines from the pump and plug the ends to prevent fluid contamination.
8. Remove the motor (19), see page 30.
9. See FIG. 28. Remove the screws (12), circuit board cover (34), and gasket (33). Retain the cover and screws. Discard the gasket.

NOTE: Step 10 applies to pumps with the sensor circuit option. If your pump does not have the sensor circuit, go to step 11.

10. On pumps with the sensor circuit:
 - a. See FIG. 27. Disconnect the transducer cable (25a) from J1 on the circuit board (25c). Remove and retain the ferrite (76).

- b. Disconnect the TDC sensor wires (25b) from J2 on the circuit board (25c).
 - c. Disconnect the IS circuit field wires from J2 and J3 on the circuit board, and from the two terminal blocks (46). Disconnect the position sensor wires from the two terminal blocks. Retain the terminal blocks.
 - d. Remove and retain the circuit board (25c) and TDC sensor (25b).
 - e. Unscrew the conductive strain reliefs (74a and 35) from the gear housing. Pull the 45° strain relief (35) and the transducer conduit out of the housing. Do not disconnect the transducer from the outlet port (P).
 - f. Disconnect the position sensor and attaching parts from the gear housing (1). See page 24. Be sure to remove the position sensor adapter (78). Retain these parts.
11. Unscrew the locknuts (15) from the tie rods (3). Remove the entire fluid section. Unscrew the tie rods (3) from the gear housing.
 12. See FIG. 28. Remove the setscrew (31). Unscrew the slider cylinder (2) from the gear reducer.

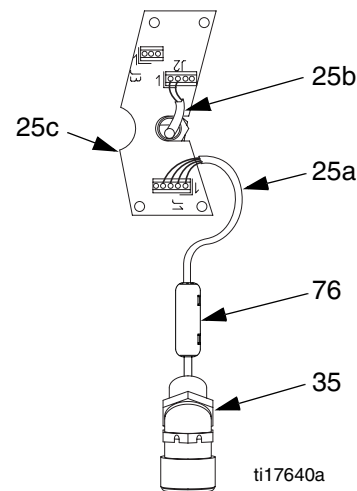

FIG. 27. Circuit Board Wire Connections

⚠ Units with a sensor circuit **must** use the conductive strain relief (74a) to ensure proper grounding of the IS field wire. See page 21.

⚠ Torque to 50-60 ft-lb (68-80 N•m).

⚠ Torque to 75-80 ft-lb (102-108 N•m).

⚠ Torque to 15-20 ft-lb (21-27 N•m).

⚠ Torque to 66-78 in-lb (7.4-8.8 N•m).

⚠ Apply antiseize lubricant to screw (5) threads. Torque key-side screw to 210-230 ft-lb (283-310 N•m) first, then torque gap side screw to 210-230 ft-lb (283-310 N•m). Torque screws an additional 2-3 times each, or until they stop turning when torqued to 210-230 ft-lb (283-310 N•m).

⚠ Apply lithium grease.

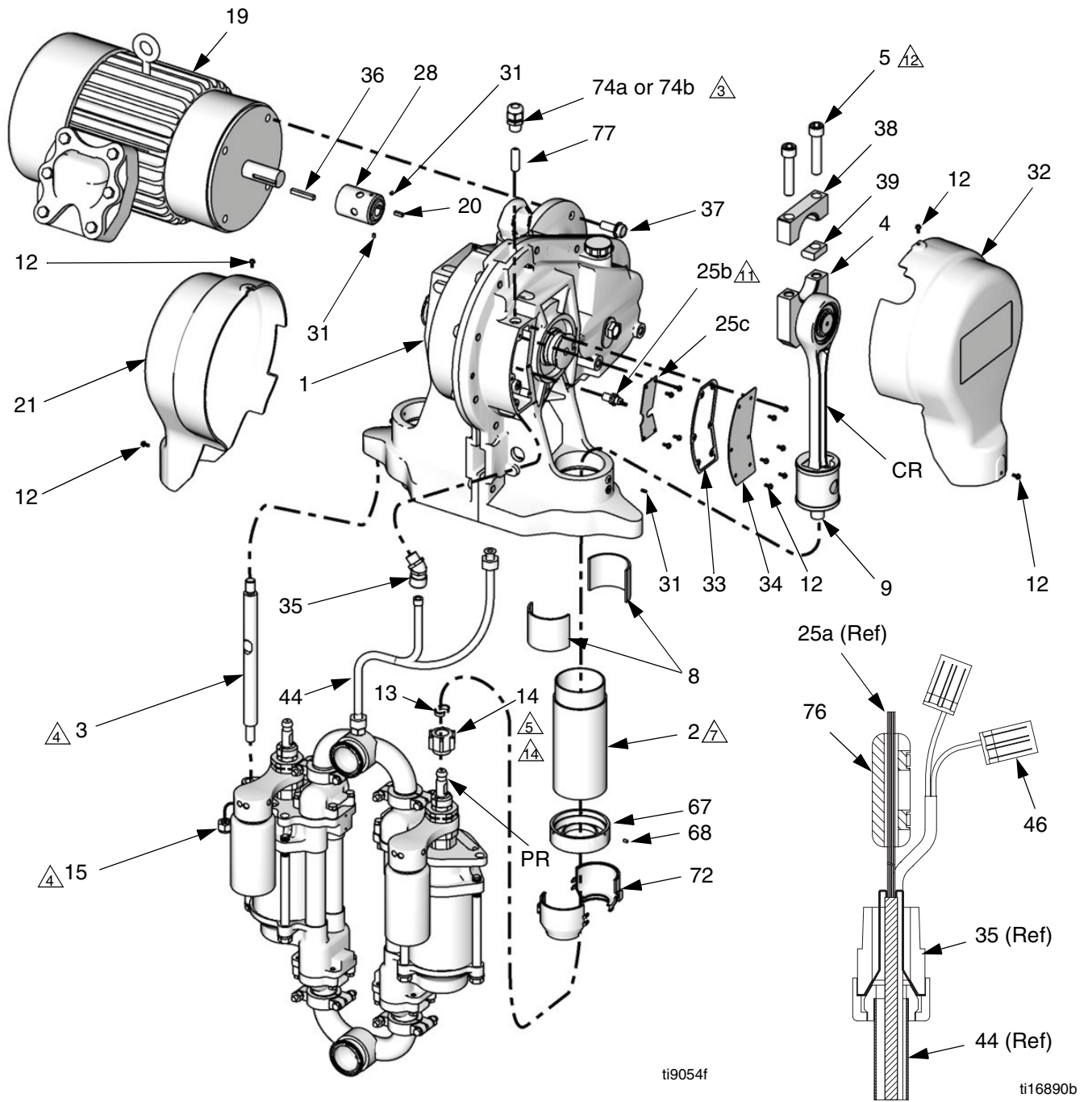

ti9054f

ti16890b

Detail of Sensor Conduit

FIG. 28: Gear Reducer Replacement

Reassembly

NOTE: Kit 15H886 includes a motor coupler (28), already installed in the gear reducer. The coupler fits all NEMA 182/184 TC Frame electric motors.

NOTE: To install an IEC 112M/B5 or 100L/B5 Frame electric motor, order Motor Adapter Kit 15J893. See TABLE 1 on page 33, and manual 311605.

1. Apply antiseize lubricant to bore of coupling.
2. Install the motor (19), see page 33.
3. See FIG. 28. Screw the slider cylinders (2) into the new gear reducer (1). Torque to 15-20 ft-lb (21-27 N•m). Install the setscrews (31). Torque to 30-35 in-lb (3.4-3.9 N•m).
4. Screw the tie rods (3) into the gear housing. Torque to 50-60 ft-lb (68-80 N•m).
5. Orient the lowers (22) to the gear reducer (1) as shown. Position the lowers on the tie rods (3). Screw the tie rod locknuts (15) onto the tie rods. Torque the locknuts to 50-60 ft-lb (68-80 N•m).
6. See FIG. 17 on page 27. Ensure that the joints between the slider bearings (8) align with the pin hole (PH) in the slider piston (9).
7. Reconnect the drive linkage. See steps 14-19 on page 27.
8. Remove the rag from the slider cylinder.
9. Turn on power and jog the motor to bring the other drive to the bottom of its stroke. Repeat procedure to connect the other lower. Reinstall the shields (72).

NOTE: Step 10 applies to pumps with the sensor circuit option. If your pump does not have the sensor circuit, go to step 11.

10. On pumps with the sensor circuit:

- a. Remove the plug from the TDC sensor port at the back of the circuit board cavity. Clean any excess sealant from the area.
- b. See FIG. 29. Apply pipe sealant and screw the TDC sensor (25b) into the port. Torque to 66-78 in-lb (7.4-8.8 N•m).

NOTE: TDC sensor nuts are locked in place to ensure correct positioning. Do not adjust.

- c. Install the circuit board (25c) and four screws (12).
- d. Connect the TDC sensor (25b) to J2 on the circuit board (25c).
- e. Install the position sensor and attaching parts in the gear housing (1). See page 24.

NOTE: The Position Sensor nuts are locked in place to ensure correct positioning. Do not adjust.

- f. Ensure that the conductive strain relief (35) is screwed tightly into the housing.
- g. Connect the transducer's cable to J1 on the circuit board (25c). Install the ferrite (76) around the transducer leadwires.
- h. Tighten the nut (N) on the conductive strain relief (35) securely to ensure that the ground wire (G) has firm metal-to-metal contact between the nut and bushing (B).
- i. Ensure that the conductive strain relief (74a) is screwed tightly into the housing. Units with a sensor circuit **must** use the conductive strain relief to ensure proper grounding of the IS field wire.

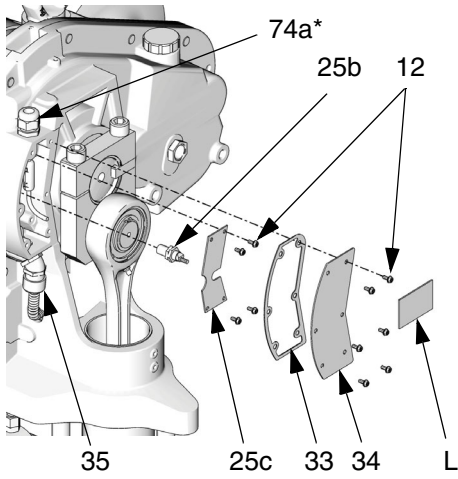

ti8725b

Circuit Board Location

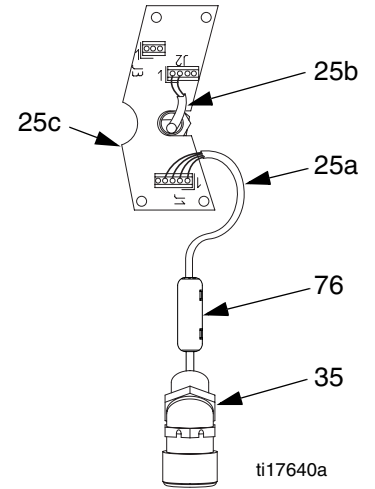

ti17640a

Circuit Board Wire Connections

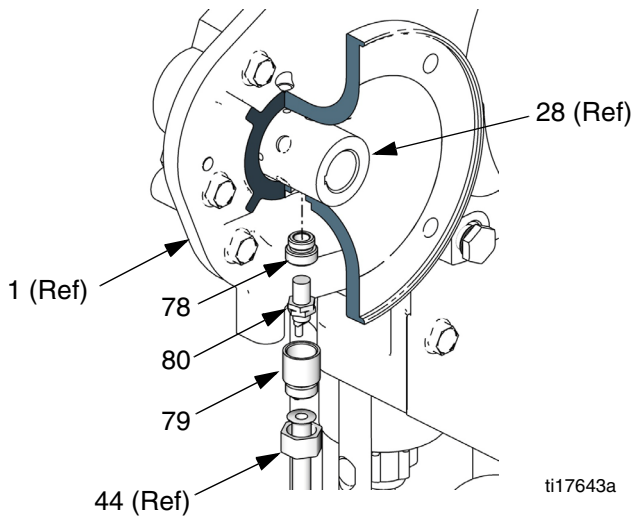

ti17643a

Position Sensor Parts and Location

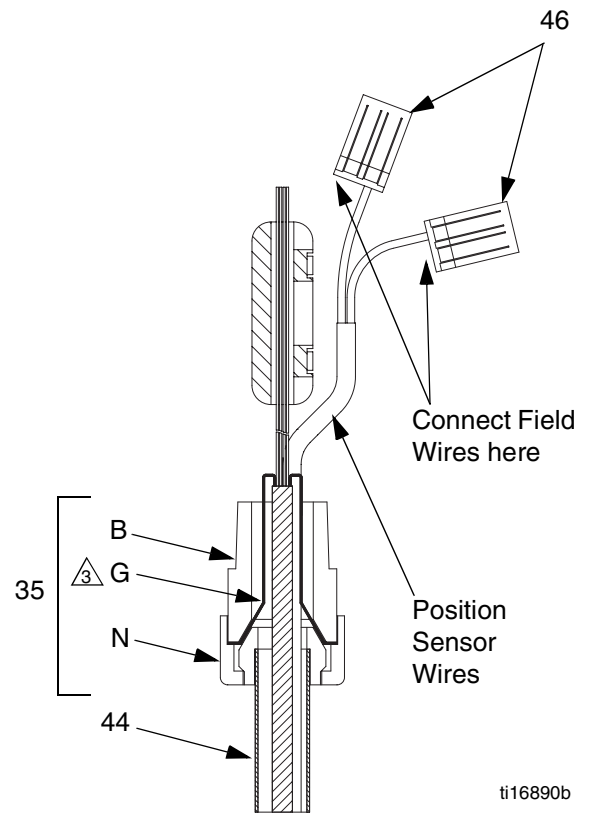

ti16890b

Pressure Transducer Grounding Schematic, and Position Sensor Terminals

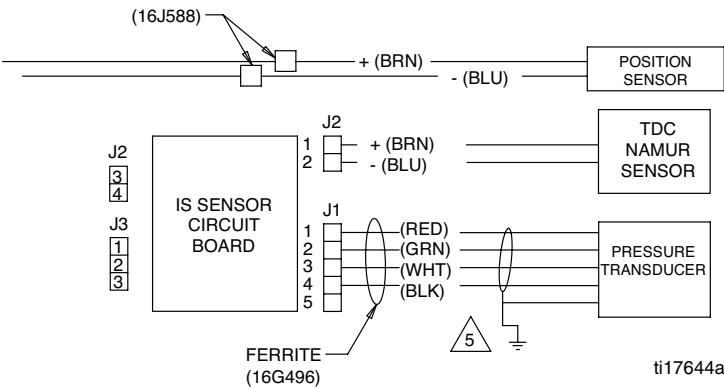

ti17644a

⚠ Land shield drain and foil to conductive strain relief.

⚠ Tighten nut (N) securely to ensure that the shield and drain wire (G) has firm metal-to-metal contact between the nut and bushing (B).

FIG. 29. Sensor Circuit Installation

Repair

- j. Thread the IS field wire through the conductive strain relief (74a). Connect the TDC wires to J2, the transducer wires to J3, and the position sensor wires to the two terminal blocks (46). See FIG. 29 and the **Electrical Diagrams**, page 12.
 - k. See FIG. 30. Tighten the nut (N) on the conductive strain relief (74a) securely. Install the ferrite (77) on the field wire (F), not more than 2 in. (51 mm) from the bottom of the conductive strain relief (74a). Install the ground wire (G) to the grounding screw in the junction box.
11. Install the new gasket (33), the cover (34), and six screws (12).
 12. Reinstall the covers (32 and 21) and screws (12).
 13. Add 2 quarts of gear oil, Part No. 288414.

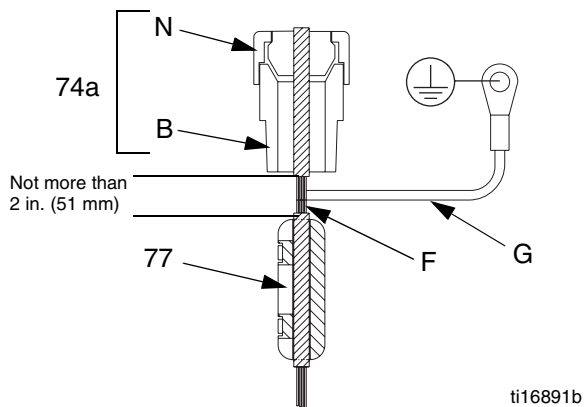
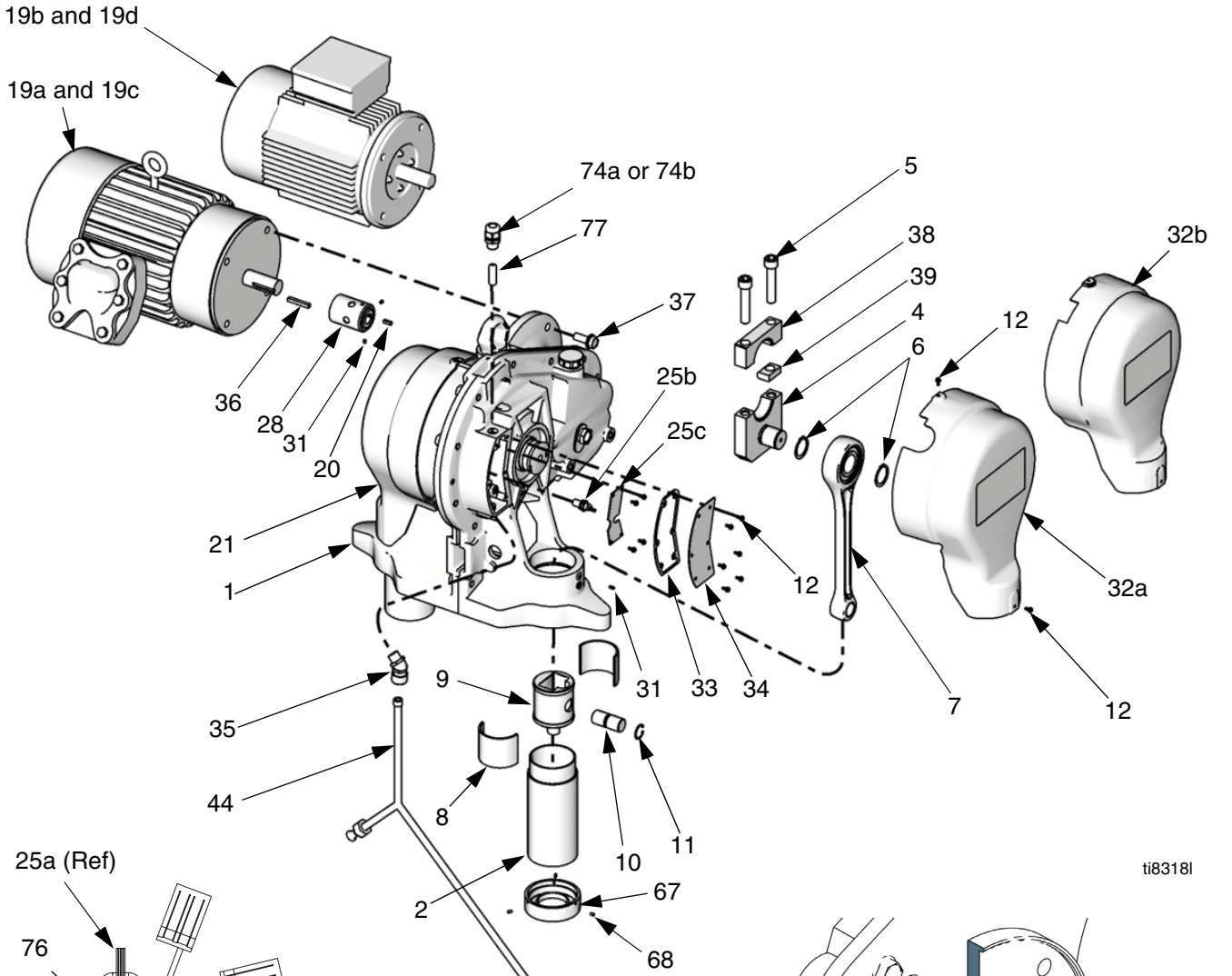

FIG. 30. IS Circuit Field Wire

Parts

Drive Section



ti8318l

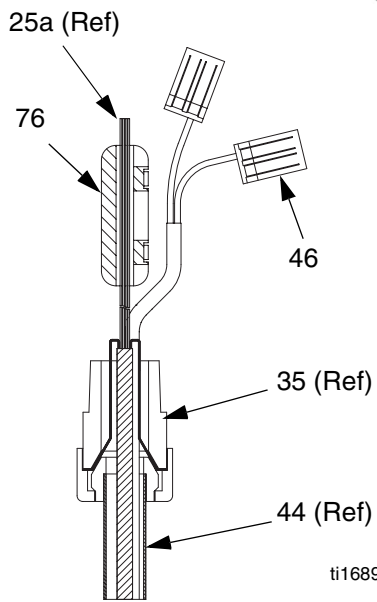

ti16890b

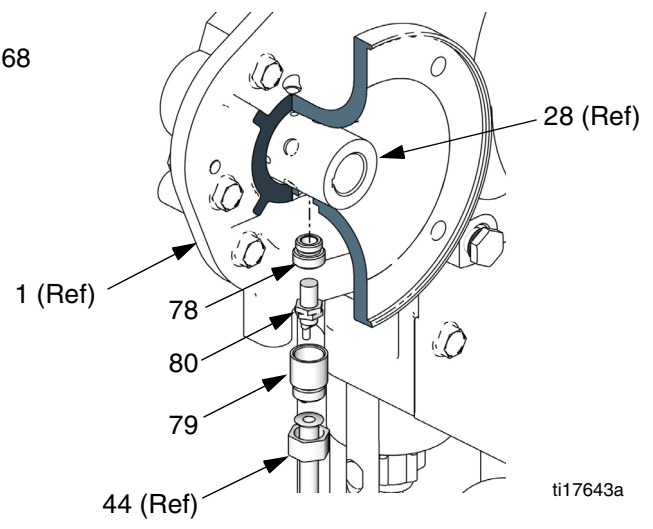

ti17643a

Position Sensor Parts and Location

Detail of Sensor Conduit

Fluid Section

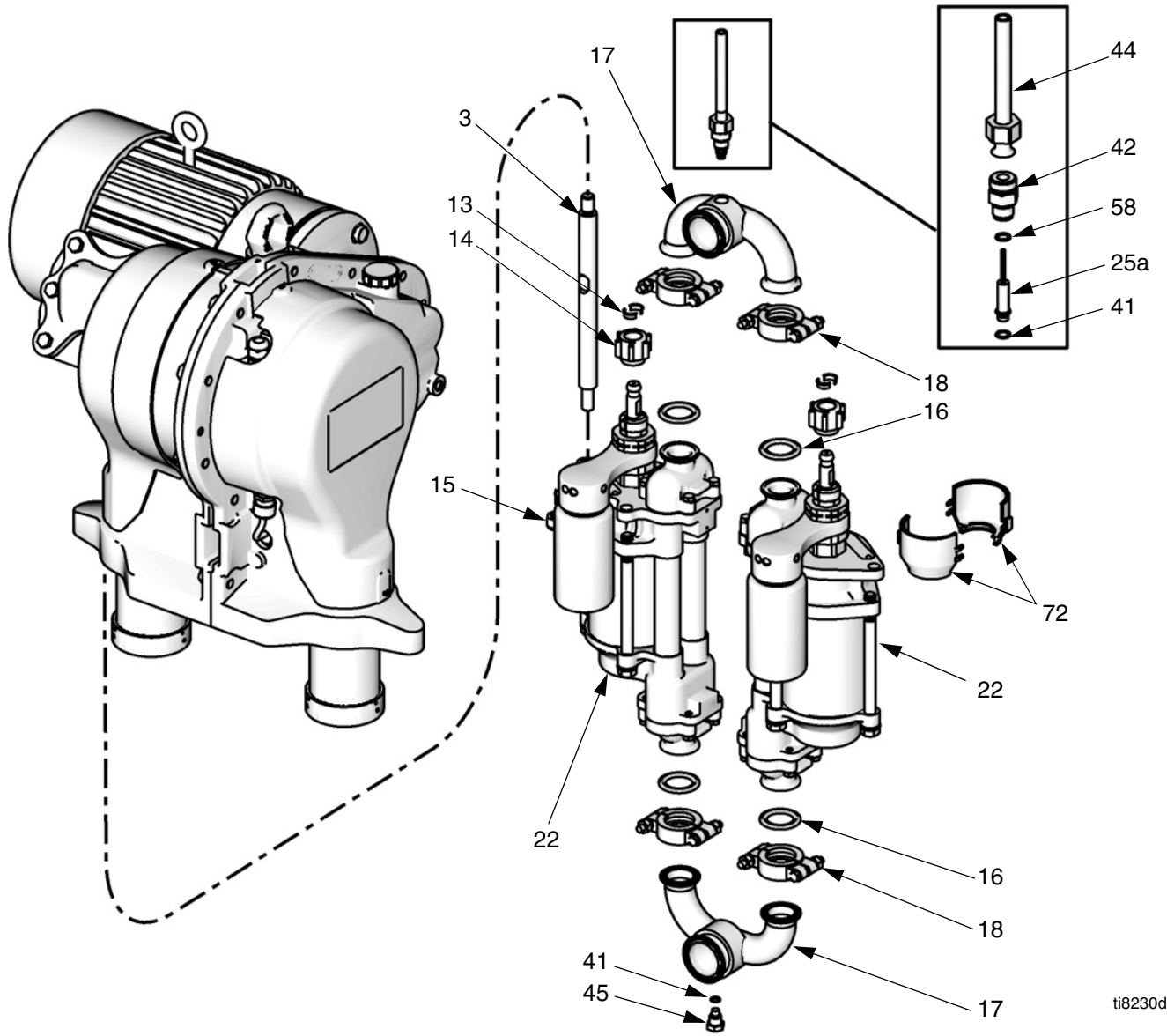

ti8230d

Common Parts

Ref. No.	Part No.	Description	Qty	Ref. No.	Part No.	Description	Qty	
1	15H886	KIT, 75:1 gear reducer; <i>E-Flo 2000/3000/4000 only</i> ; see 311615	1	22	24F417	LOWER, 750 cc, chrome; see page 46 for applicable models; see 3A0539	2	
	289550	KIT, 75:1 gear reducer; <i>E-Flo 1500 only</i> ; see 311615	1		24F428	LOWER, 1000 cc, chrome; see page 46 for applicable models; see 3A0539	2	
2†	n/a	CYLINDER, slider	2		24F436	LOWER, 1500 cc, chrome; see page 46 for applicable models; see 3A0539	2	
3	n/a	ROD, tie	6		24F444	LOWER, 2000 cc, chrome; see page 46 for applicable models; see 3A0539	2	
4‡	n/a	ARM, crank	2		24F418	LOWER, 750 cc, MaxLife; see page 46 for applicable models; see 3A0539	2	
5*‡	n/a	SCREW, cap, socket-head; 5/8-11 x 3 in. (76 mm)	4		24F429	LOWER, 1000 cc, MaxLife; see page 46 for applicable models; see 3A0539	2	
6*‡	106082	RING, retaining	4		24F437	LOWER, 1500 cc, MaxLife; see page 46 for applicable models; see 3A0539	2	
7*	n/a	ROD, connecting	2		24F445	LOWER, 2000 cc, MaxLife; see page 46 for applicable models; see 3A0539	2	
8*†	15H882	KIT, slider bearing; includes 4 bearings and items 5 and 12; see 311616	4	23▲	15H875	LABEL, warning icons (not shown)	1	
9*	n/a	PISTON, slider	2	25◆	24J305	KIT, sensor circuit; includes items 25a-25c, 12, 32, 33, 35, 41, 42, 44, 46, 58, 74a, 76-80; see page 46 for applicable models; see 311603	1	
10*	n/a	PIN, lower connecting rod	2		25a	15H876	KIT, pressure transducer replacement; see 311600	1
11*	n/a	RING, retaining	2	25b	15H877	KIT, TDC replacement; see 311601	1	
12*‡	116719	SCREW, 8-32 hex washer head <i>Pumps without sensor circuit (25)</i> <i>Pumps with sensor circuit (25)</i>	10 14	25c	n/a	CIRCUIT BOARD	1	
13	184128	COLLAR, coupling	4	27	n/a	PLUG, TDC port; <i>not shown; used only on pumps without sensor circuit (25)</i>	1	
14	184059	NUT, coupling	2	28	15H880	KIT, motor coupler; includes items 20, 31, 37; see page 46 for applicable models; see 311605	1	
15†	108683	NUT, lock, hex	6	31†	100664	SCREW, set, socket-head; 1/4-20 x 1/2 in. (13 mm) <i>Pumps with motors</i> <i>Pumps without motors</i>	4 2	
16†	120351	GASKET, sanitary	4	32	n/a	COVER, crank arm; side opposite motor	1	
17	253343	MANIFOLD	2	33	n/a	GASKET, circuit board	1	
18	120350	CLAMP, sanitary, 1.5	4	34	n/a	COVER, circuit board	1	
19a	255225	MOTOR, electric, 5HP, 230/460V, 60 Hz, UL/CSA; see page 46 for applicable models; includes item 37; see 311613	1	35	n/a	CONNECTOR, strain relief, 45°; <i>used only on pumps with sensor circuit (25)</i>	1	
19b	255226	MOTOR, electric, 5HP, 230/400V, 50 Hz, ATEX; see page 46 for applicable models; includes items 36 and 37; see 311613	1					
19c	289551	MOTOR, electric, 3HP, 230/460V, 60 Hz, UL/CSA; see page 46 for applicable models; includes items 36 and 37; see 311613	1					
19d	289552	MOTOR, electric, 3HP, 230/400V, 50 Hz, ATEX; see page 46 for applicable models; includes items 36 and 37; see 311613	1					
20	n/a	KEY, square; 0.188 x 0.62 in.	1					
21	n/a	COVER, crank arm, motor side	1					

Ref. No.	Part No.	Description	Qty
36	120710	KEY, square; 0.25 x 1.75 in.; for ATEX 5 HP motor (19b) only	1
37	111195	SCREW, cap, flange-head; 1/2-13 x 1.25 in. (31 mm); used only on pumps supplied with motor (19)	4
38‡	n/a	CAP, crank arm	2
39‡	n/a	KEY, crank arm	2
41†	111316	O-RING; chemically resistant fluoro-elastomer	2
42	n/a	ADAPTER, transducer; used only on pumps with sensor circuit (25)	1
44	n/a	CONDUIT, sensor; used only on pumps with sensor circuit (25)	1
45	n/a	PLUG, manifold Pumps without sensor circuit (25)	2
		Pumps with sensor circuit (25)	1
46	16J588	TERMINAL BLOCK, position sensor; used only on pumps with sensor circuit (25)	2
58	n/a	SPACER; brass; used only on pumps with sensor circuit (25)	1
67★	n/a	COLLECTOR	2
68★	n/a	SETSCREW	6
69	15H884	KIT, floor stand; includes items 69a and 69b; see this page and manual 406638; see page 46 for applicable models	1
69a	n/a	SCREW, cap, hex-head; 1/2-13 x 1.0 in. (25 mm)	4
69b	16J477	CAP, square	5
72	24F253	KIT, coupler shield; see 406876	2
73	16E083	SPACER, open wet cup (shipped loose; not shown)	2
74a	16J487	BUSHING, strain relief; steel; required on pumps with sensor circuit (25)	1
74b	117745	BUSHING, strain relief; nylon; not for use on pumps with sensor circuit (25)	1
76	16G496	FERRITE; for pressure transducer cable; used only on pumps with sensor circuit (25)	1
77	15D906	FERRITE; shipped loose, for IS circuit field wiring; used only on pumps with sensor circuit (25)	1
78	n/a	ADAPTER, pressure sensor; used only on pumps with sensor circuit (25)	1
79	n/a	SLEEVE, pressure sensor; used only on pumps with sensor circuit (25)	1
80	16K088	POSITION SENSOR; used only on pumps with sensor circuit (25)	1

Parts designated n/a are not available separately.

* Parts included in Drive Linkage Rebuild Kit 15H873 (purchase separately). Order two kits to rebuild both drive linkage assemblies. Includes manual 311598.

† Parts included in Slider Cylinder Rebuild Kit 15H874 (purchase separately). Order two kits to rebuild both slider cylinder assemblies. Includes manual 311598.

‡ Parts included in Crank Arm Rebuild Kit 15H883 (purchase separately). Order two kits to rebuild both crank arm assemblies. Includes manual 311604.

★ Parts included in Slider Cylinder Collector Kit 247341 (purchase separately). Order one kit to rebuild both slider cylinder collector assemblies. Includes manual 311607.

▲ Replacement Danger and Warning labels, tags, and cards are available at no cost.

◆ Part No. 24J305 Sensor Circuit Kit is for Series D and later pumps only. For Series C and earlier pumps, order Part No. 15J755 Sensor Circuit Kit. See manual 311603 for both kits.

Detail of Floor Stand Kit (69)

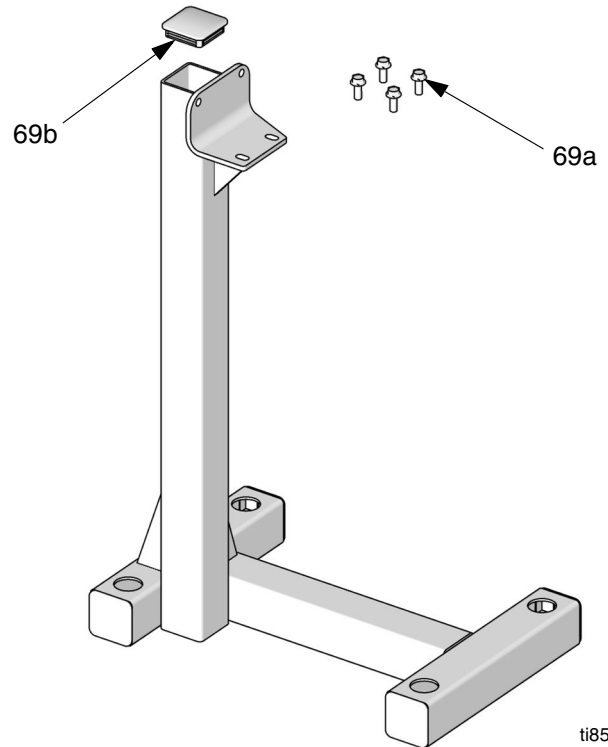

ti8550c

Model-Specific Parts

NOTE: A checkmark (✓) indicates an item is used on your pump. Shaded boxes indicate that an item is not used.

Pump Part No.	Series	Motor Kit (19)				Lower (22)	Sensor Circuit (25)	Coupler/Motor Mounting Kit (28)	Floor Stand Kit (69)
		255226	255225	289552	289551				
EP0010	B					24F428			
EP0011	B					24F428			✓
EP0020	B					24F436			
EP0021	B					24F436			✓
EP0030	B					24F444			
EP0031	B					24F444			✓
EP0040	B					24F429			
EP0041	B					24F429			✓
EP0050	B					24F437			
EP0051	B					24F437			✓
EP0060	B					24F445			
EP0061	B					24F445			✓
EP0070	B					24F417			
EP0071	B					24F417			✓
EP00H1	B					24F446			✓
EP0080	A					24F418			
EP0081	A					24F418			✓
EP0110	D					24F428	✓		
EP0111	D					24F428	✓		✓
EP0120	D					24F436	✓		
EP0121	D					24F436	✓		✓
EP0130	D					24F444	✓		
EP0131	D					24F444	✓		✓
EP0140	D					24F429	✓		
EP0141	D					24F429	✓		✓
EP0150	D					24F437	✓		
EP0151	D					24F437	✓		✓
EP0160	D					24F445	✓		
EP0161	D					24F445	✓		✓
EP0170	D					24F417	✓		
EP0171	D					24F417	✓		✓
EP0180	D					24F418	✓		
EP0181	D					24F418	✓		✓

Pump Part No.	Series	Motor Kit (19)				Lower (22)	Sensor Circuit (25)	Coupler/Motor Mounting Kit (28)	Floor Stand Kit (69)
		255226	255225	289552	289551				
EP1010	C	✓				24F428		✓	
EP1011	B	✓				24F428		✓	✓
EP1020	C	✓				24F436		✓	
EP1021	B	✓				24F436		✓	✓
EP1030	C	✓				24F444		✓	
EP1031	B	✓				24F444		✓	✓
EP1040	C	✓				24F429		✓	
EP1041	B	✓				24F429		✓	✓
EP1050	C	✓				24F437		✓	
EP1051	B	✓				24F437		✓	✓
EP1060	C	✓				24F445		✓	
EP1061	B	✓				24F445		✓	✓
EP3070	B			✓		24F417		✓	
EP3071	B			✓		24F417		✓	✓
EP3080	A			✓		24F418		✓	
EP3081	A			✓		24F418		✓	✓
EP1110	D	✓				24F428	✓	✓	
EP1111	D	✓				24F428	✓	✓	✓
EP1120	D	✓				24F436	✓	✓	
EP1121	D	✓				24F436	✓	✓	✓
EP1130	D	✓				24F444	✓	✓	
EP1131	D	✓				24F444	✓	✓	✓
EP1140	D	✓				24F429	✓	✓	
EP1141	D	✓				24F429	✓	✓	✓
EP1150	D	✓				24F437	✓	✓	
EP1151	D	✓				24F437	✓	✓	✓
EP1160	D	✓				24F445	✓	✓	
EP1161	D	✓				24F445	✓	✓	✓
EP31H0	A			✓		24F052	✓	✓	
EP3170	D			✓		24F417	✓	✓	
EP3171	D			✓		24F417	✓	✓	✓
EP3180	D			✓		24F418	✓	✓	
EP3181	D			✓		24F418	✓	✓	✓

Parts

Pump Part No.	Series	Motor Kit (19)				Lower (22)	Sensor Circuit (25)	Coupler/Motor Mounting Kit (28)	Floor Stand Kit (69)
		255226	255225	289552	289551				
EP2010	B		✓			24F428		✓	
EP2011	B		✓			24F428		✓	✓
EP2020	B		✓			24F436		✓	
EP2021	B		✓			24F436		✓	✓
EP2030	B		✓			24F444		✓	
EP2031	B		✓			24F444		✓	✓
EP2040	B		✓			24F429		✓	
EP2041	B		✓			24F429		✓	✓
EP2050	B		✓			24F437		✓	
EP2051	B		✓			24F437		✓	✓
EP2060	B		✓			24F445		✓	
EP2061	B		✓			24F445		✓	✓
EP4070	B				✓	24F417		✓	
EP4071	B				✓	24F417		✓	✓
EP4080	A				✓	24F418		✓	
EP4081	A				✓	24F418		✓	✓
EP2110	D		✓			24F428	✓	✓	
EP2111	D		✓			24F428	✓	✓	✓
EP2120	D		✓			24F436	✓	✓	
EP2121	D		✓			24F436	✓	✓	✓
EP2130	D		✓			24F444	✓	✓	
EP2131	D		✓			24F444	✓	✓	✓
EP2140	D		✓			24F429	✓	✓	
EP2141	D		✓			24F429	✓	✓	✓
EP2150	D		✓			24F437	✓	✓	
EP2151	D		✓			24F437	✓	✓	✓
EP2160	D		✓			24F445	✓	✓	
EP2161	D		✓			24F445	✓	✓	✓
EP4170	D				✓	24F417	✓	✓	
EP4171	D				✓	24F417	✓	✓	✓
EP4180	D				✓	24F418	✓	✓	
EP4181	D				✓	24F418	✓	✓	✓

Gear Reducer

Ref. No.	Part No.	Description	Qty
109*	n/a	SEAL, input shaft	1
114	15H525	CAP, fill	1
115	n/a	SIGHTGLASS,	1
116*	n/a	SEAL, output	4
118*	15H432	PLUG, oil drain, with gasket	1

* These parts are included in Gear Reducer Seal Kit 15H871. See manual 311597.

NOTE: To replace the entire gear reducer, order one of the following kits:

- 15H886 Gear Reducer Replacement Kit, for E-Flo 2000/3000/4000. See manual 311615.
- 289550 Gear Reducer Replacement Kit, for E-Flo 1500. See manual 311615.

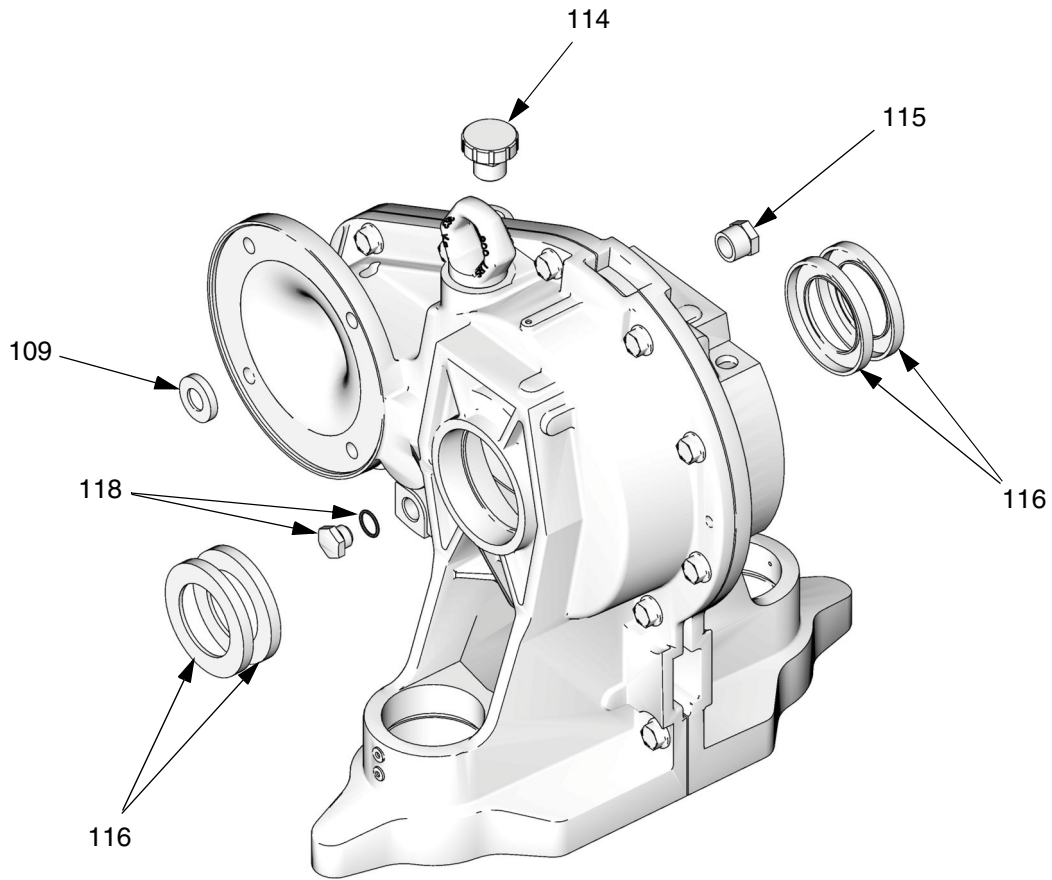

ti8320a

Technical Data

Maximum Working Pressure	<i>E-Flo 1500</i> : 425 psi (2.93 MPa, 29.3 bar) <i>E-Flo 2000</i> : 460 psi (3.22 MPa, 32.2 bar) <i>E-Flo 3000</i> : 330 psi (2.31 MPa, 23.1 bar) <i>E-Flo 4000</i> : 250 psi (1.75 MPa, 17.5 bar)
Maximum Fluid Temperature	150°F (66°C)
Electrical Requirements	<i>European Models</i> : 230/400 Vac, 3 phase, 20 A/15 A <i>North American Models</i> : 230/460 Vac, 3 phase, 20 A/15 A
Ambient Temperature Range	32-104°F (0-40°C)
Maximum Fluid Output	See charts on page 51.
Fluid Inlet and Outlet Size	2 in. Tri-clamp
Gear Reducer Oil Capacity	2 quarts (1.9 liters)
Required Gear Reducer Lubricant	ISO VG220 grade oil (Graco Part No. 288414)
Weight	<i>Pump</i> : 550 lb (249 kg)
Wetted Parts	<i>Lower</i> : see manual 3A0539 300 Series SST, CV-75, 17-4 PH SST, PTFE
Electric Motor	<i>E-Flo 1500</i> : 3 HP, 1800 rpm (60 Hz) or 1500 rpm (50 Hz), NEMA 182 TC Frame <i>E-Flo 2000/3000/4000</i> : 5 HP, 1800 rpm (60 Hz) or 1500 rpm (50 Hz), NEMA 184 TC Frame
Maximum Production Motor Speed	1500 rpm (50 Hz) 1800 rpm (60 Hz)
Maximum Motor Torque	<i>E-Flo 1500</i> : 9.1 ft-lb (12.3 N•m) <i>E-Flo 2000/3000/4000</i> : 15 ft-lb (20.3 N•m)
Gear Reduction Ratio	75.16:1

NOTE: All brand names or marks are used for identification purposes and are the trademarks of their respective owners.

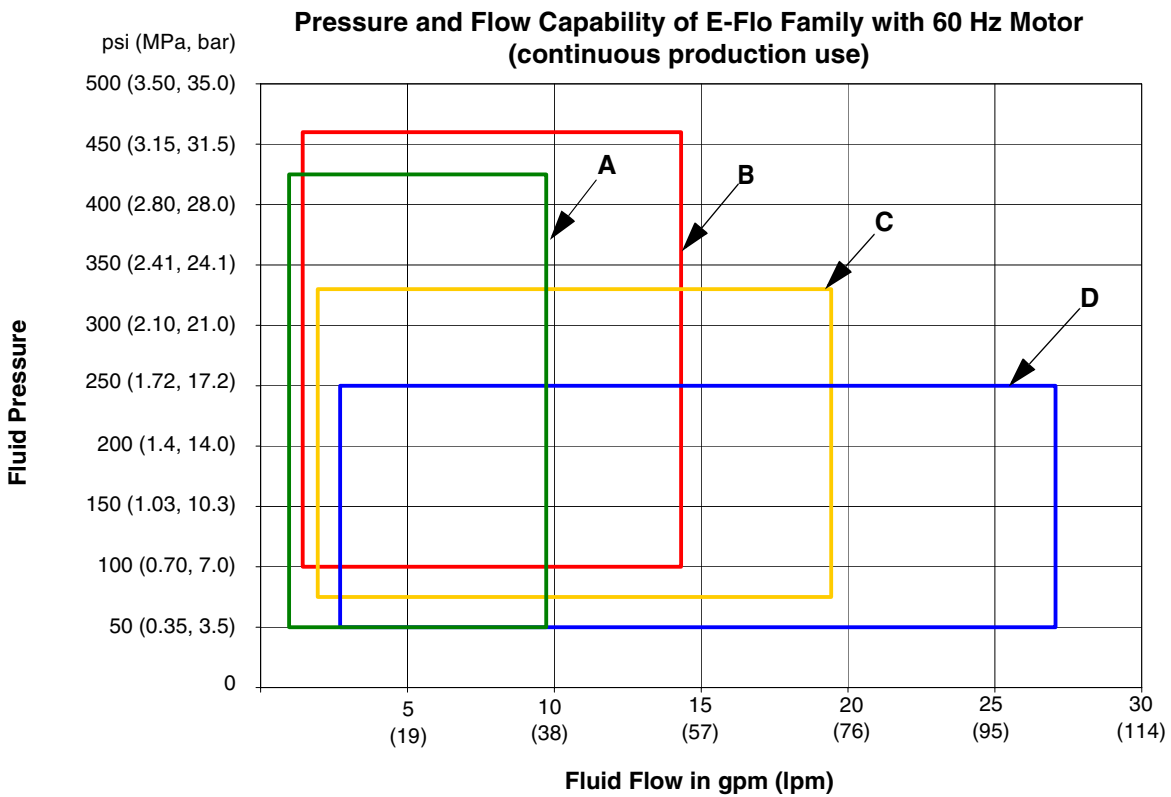
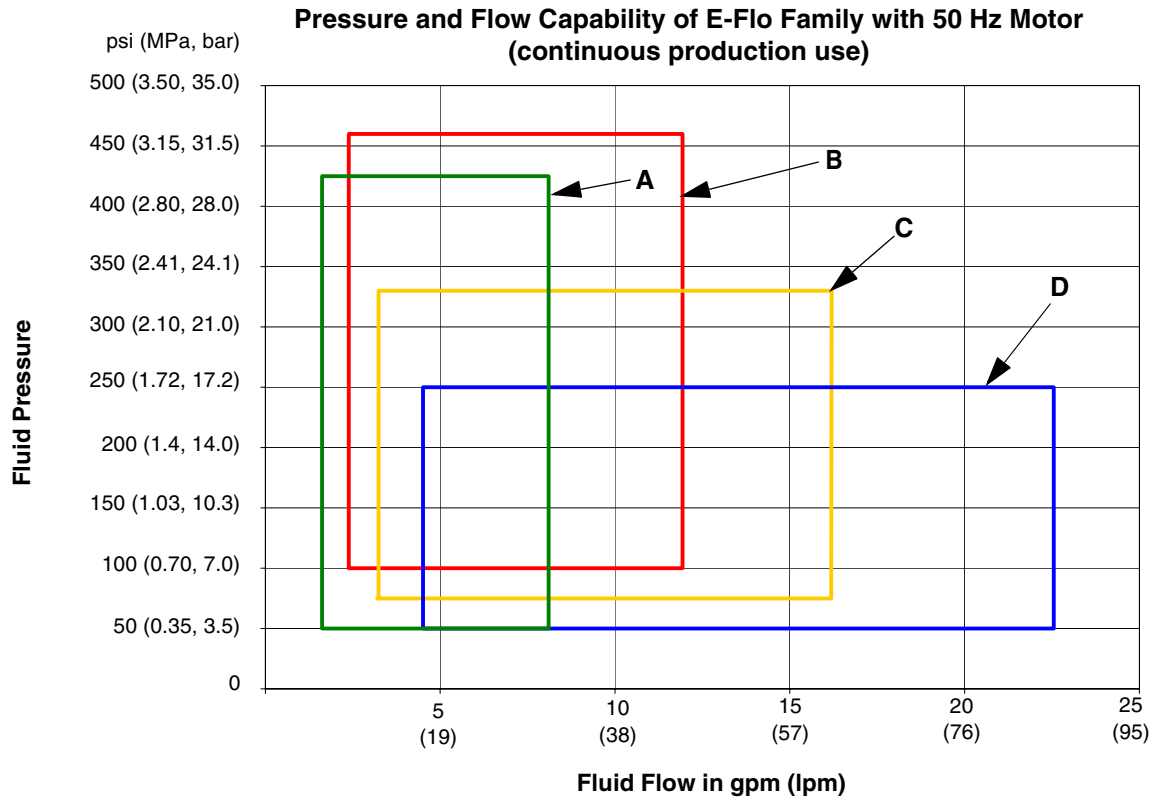

Graco Standard Warranty

Graco warrants all equipment referenced in this document which is manufactured by Graco and bearing its name to be free from defects in material and workmanship on the date of sale to the original purchaser for use. With the exception of any special, extended, or limited warranty published by Graco, Graco will, for a period of twelve months from the date of sale, repair or replace any part of the equipment determined by Graco to be defective. This warranty applies only when the equipment is installed, operated and maintained in accordance with Graco's written recommendations.

This warranty does not cover, and Graco shall not be liable for general wear and tear, or any malfunction, damage or wear caused by faulty installation, misapplication, abrasion, corrosion, inadequate or improper maintenance, negligence, accident, tampering, or substitution of non-Graco component parts. Nor shall Graco be liable for malfunction, damage or wear caused by the incompatibility of Graco equipment with structures, accessories, equipment or materials not supplied by Graco, or the improper design, manufacture, installation, operation or maintenance of structures, accessories, equipment or materials not supplied by Graco.

This warranty is conditioned upon the prepaid return of the equipment claimed to be defective to an authorized Graco distributor for verification of the claimed defect. If the claimed defect is verified, Graco will repair or replace free of charge any defective parts. The equipment will be returned to the original purchaser transportation prepaid. If inspection of the equipment does not disclose any defect in material or workmanship, repairs will be made at a reasonable charge, which charges may include the costs of parts, labor, and transportation.

THIS WARRANTY IS EXCLUSIVE, AND IS IN LIEU OF ANY OTHER WARRANTIES, EXPRESS OR IMPLIED, INCLUDING BUT NOT LIMITED TO WARRANTY OF MERCHANTABILITY OR WARRANTY OF FITNESS FOR A PARTICULAR PURPOSE.

Graco's sole obligation and buyer's sole remedy for any breach of warranty shall be as set forth above. The buyer agrees that no other remedy (including, but not limited to, incidental or consequential damages for lost profits, lost sales, injury to person or property, or any other incidental or consequential loss) shall be available. Any action for breach of warranty must be brought within two (2) years of the date of sale.

GRACO MAKES NO WARRANTY, AND DISCLAIMS ALL IMPLIED WARRANTIES OF MERCHANTABILITY AND FITNESS FOR A PARTICULAR PURPOSE, IN CONNECTION WITH ACCESSORIES, EQUIPMENT, MATERIALS OR COMPONENTS SOLD BUT NOT MANUFACTURED BY GRACO. These items sold, but not manufactured by Graco (such as electric motors, switches, hose, etc.), are subject to the warranty, if any, of their manufacturer. Graco will provide purchaser with reasonable assistance in making any claim for breach of these warranties.

In no event will Graco be liable for indirect, incidental, special or consequential damages resulting from Graco supplying equipment hereunder, or the furnishing, performance, or use of any products or other goods sold hereto, whether due to a breach of contract, breach of warranty, the negligence of Graco, or otherwise.

FOR GRACO CANADA CUSTOMERS

The Parties acknowledge that they have required that the present document, as well as all documents, notices and legal proceedings entered into, given or instituted pursuant hereto or relating directly or indirectly hereto, be drawn up in English. Les parties reconnaissent avoir convenu que la rédaction du présente document sera en Anglais, ainsi que tous documents, avis et procédures judiciaires exécutés, donnés ou intentés, à la suite de ou en rapport, directement ou indirectement, avec les procédures concernées.

Graco Information

For the latest information about Graco products, visit www.graco.com.

For patent information, see www.graco.com/patents.

TO PLACE AN ORDER, contact your Graco distributor or call to identify the nearest distributor.

Phone: 612-623-6921 **or Toll Free:** 1-800-328-0211 **Fax:** 612-378-3505

All written and visual data contained in this document reflects the latest product information available at the time of publication. Graco reserves the right to make changes at any time without notice.

Original instructions. This manual contains English. MM 311594

Graco Headquarters: Minneapolis

International Offices: Belgium, China, Japan, Korea

GRACO INC. AND SUBSIDIARIES • P.O. BOX 1441 • MINNEAPOLIS MN 55440-1441 • USA
Copyright 2007, Graco Inc. All Graco manufacturing locations are registered to ISO 9001.

www.graco.com

Revision Z, August 2014